

GCSE MATHEMATICS

Aiming for Grade 7

REVISION BOOKLET

Exam Dates:



Name: _____

Teacher: _____

Contents

	Page:
Number:	
<u>Fractional laws of indices</u>	3
<u>Standard form</u>	5
<u>Simplifying surds</u>	7
<u>Rationalising the denominator</u>	10
Algebra:	
<u>Perpendicular graphs</u>	12
<u>Exponential functions</u>	15
<u>Types of graphs</u>	18
<u>Transformations of graphs</u>	21
<u>Factorising harder quadratics</u>	24
<u>Algebraic fractions</u>	26
<u>Quadratic formula</u>	29
<u>Completing the square</u>	33
<u>Inequality regions</u>	36
Shape, Space and Measure:	
<u>Circle theorems</u>	40
<u>Enlargement (negative/fractional scale factors)</u>	45
<u>Column vectors</u>	49
<u>Sine and cosine rules</u>	51
<u>Arcs and sectors</u>	56
<u>Length, area and volume scale factors</u>	59
<u>Volumes of frustums</u>	63
Data Handling:	
<u>Cumulative frequency and box plots</u>	65
<u>Petersen capture-recapture method</u>	70
Probability:	
<u>Conditional probability</u>	74
<u>Product rule for counting</u>	79
Ratio and Proportion:	
<u>Direct and inverse proportion</u>	82
<u>Reverse percentages</u>	85
<u>Converting recurring decimals to fractions</u>	88

Fractional Laws of Indices

Things to remember:

- The exam question will use the word “simplify”.
- If the exam question has the words “work out the value of”, or “evaluate” it means the answer is a number.

$$a^{1/2} = \sqrt{a}$$

$$a^{1/3} = \sqrt[3]{a}$$

$$a^{m/n} = \sqrt[n]{a^m}$$

Questions:

1. Find the value of $49^{1/2}$

.....
(Total 1 mark)

2. Find the value of $64^{1/2}$

.....
(Total 1 mark)

3. Find the value of $8^{1/3}$

.....
(Total 1 mark)

4. Find the value of $64^{1/3}$

.....
(Total 1 mark)

5. Find the value of $25^{-1/2}$

.....
(Total 1 mark)

6. Find the value of $27^{-1/3}$

.....
(Total 1 mark)

7. Find the value of $\left(\frac{1}{9}\right)^{-1/2}$

.....
(Total 1 mark)

8. Find the value of $16^{3/2}$

.....
(Total 2 marks)

9. Find the value of $27^{-2/3}$

.....
(Total 2 marks)

10. Find the value of $(8x^6)^{-2/3}$

.....
(Total 2 marks)

11. Find the value of $\left(\frac{8}{27}\right)^{-2/3}$

.....
(Total 2 marks)

12. Find the value of $\left(\frac{1}{4}\right)^{-5/2}$

.....
(Total 2 marks)

13. Find the value of $\sqrt[3]{2 \times 32 \times 10^{12}}$

.....
(Total 2 marks)

14. Given that $3^{-n} = 0.2$
Find the value of $(3^n)^2$

.....
(Total 2 marks)

Standard Form

Things to remember:

- Standard form gives us a more concise way of writing really big or really small numbers.
- It must be in the form $a \times 10^n$ where $1 \leq a < 10$ and n is an integer.
- For example:
 - $45\,000\,000 = 4.5 \times 10^7$
 - $0.000\,05 = 5 \times 10^{-5}$

Questions:

1. A teacher asks Radwan and Charlie to convert 101 376 into standard form.

a) Radwan writes 10.1376×10^4

Is Radwan correct? You must give a reason for your answer.

.....

.....

(1)

b) Charlie writes 1.01376×10^{-5}

Is Charlie correct? You must give a reason for your answer.

.....

.....

(1)

(Total 2 marks)

2. Work out $(4 \times 10^6) \times (5 \times 10^7)$

Give your answer in standard form.

.....

(Total 2 marks)

3. Work out $(3 \times 10^8) \div (6 \times 10^{-2})$

Give your answer in standard form.

.....

(Total 2 marks)

4. Work out $\frac{(4.1 \times 10^5) \times (3.7 \times 10^4)}{2 \times 10^{-6}}$
Give your answer in standard form.

.....
(Total 2 marks)

5. One electron has a mass of 9.1×10^{-31} grams.
Calculate the mass of 100 electrons.
Give your answer in standard form.

.....
(Total 2 marks)

6. The area of India is 3.3×10^6 km²
The area of France is 5.5×10^5 km²
How many times larger is India than France?

.....
(Total 2 marks)

7. Jupiter is approximately 7.8×10^8 kilometres from the Sun.
The speed of light is approximately 3×10^8 metres per second.
Calculate the time it would take light to travel from the Sun to Jupiter.
Give your answer to the nearest minute.

.....
(Total 3 marks)

Simplifying Surds

Things to remember:

- $\sqrt{\quad}$ means square root.
- Surds can be simplified if they have a square factor.
- When expanding brackets, use the grid method to make things easier to manage.

Questions:

1. Work out the following, giving your answers in their simplest form:

a) $\sqrt{3} \times \sqrt{2}$

.....
(1)

b) $\sqrt{24} \div \sqrt{6}$

.....
(1)

c) $2\sqrt{6} \times 3\sqrt{6}$

.....
(2)

d) $10\sqrt{8} \div 2\sqrt{2}$

.....
(2)

(Total 6 marks)

2. Write $\sqrt{45}$ in the form $k\sqrt{5}$, where k is an integer.

.....
(Total 1 mark)

3. Write $\sqrt{72}$ in its simplest form.

.....
(Total 1 mark)

4. Write $5\sqrt{27}$ in the form $k\sqrt{3}$, where k is an integer.

.....
(Total 1 mark)

5. Simplify fully:

a) $\sqrt{72} + \sqrt{50}$

.....
(2)

b) $\sqrt{72} - \sqrt{32}$

.....
(2)
(Total 4 marks)

6. Expand and simplify $(2 + \sqrt{3})(2 - \sqrt{3})$

.....
(Total 2 marks)

7. Expand and simplify $(\sqrt{a} + \sqrt{b})(\sqrt{a} - \sqrt{b})$

.....
(Total 2 marks)

8. Expand and simplify $(2 + 2\sqrt{5})(3 - \sqrt{5})$

.....
(Total 2 marks)

9. Expand and simplify $(3 + \sqrt{8})(4 + \sqrt{2})$
Give your answer in the form $a + b\sqrt{2}$ where a and b are integers

.....
(Total 2 marks)

10. Work out $(\sqrt{3} - \sqrt{2})^2$

.....
(Total 2 marks)

11. Show that $(\sqrt{2} + 3\sqrt{8})^2 = 98$

.....
(Total 2 marks)

Rationalising the Denominator

Things to remember:

- To rationalise the denominator, find an equivalent fraction where the denominator is rational.
- Multiply the numerator and denominator by the surd that is a factor of the denominator.

Questions:

1. Rationalise the denominator of $\frac{1}{\sqrt{7}}$

.....
(Total 1 mark)

2. Write $\frac{\sqrt{18} + 10}{\sqrt{2}}$ in the form $a + b\sqrt{3}$ where a and b are integers.

.....
(Total 2 marks)

3. Rationalise the denominator of $\frac{3}{2\sqrt{5}}$

.....
(Total 1 mark)

4. Rationalise the denominator of $\frac{x}{\sqrt{x}}$

.....
(Total 2 mark)

5. Work out $\frac{(5 + \sqrt{3})(5 - \sqrt{3})}{\sqrt{22}}$
Give your answer in its simplest form.

.....
(Total 3 marks)

6. Show that $\frac{(4 - \sqrt{3})(4 + \sqrt{3})}{\sqrt{13}}$ simplifies to $\sqrt{13}$

.....
(Total 3 marks)

Perpendicular Graphs

Things to remember:

- If two graphs are perpendicular, the product of their gradient is -1.
- Remember the general equation of a linear graph is $y = mx + c$, where m is the gradient and c is the y -intercept.

Questions:

1. Write down the equation of a line perpendicular to $y = 2x + 7$

.....
(Total 1 mark)

2. Write down the equation of a line perpendicular to $y = -\frac{3}{5}x - 2$

.....
(Total 1 mark)

3. Here are the equations of five straight lines.

Line A	$y + 3x = 4$
Line B	$2y = x + 1$
Line C	$y + 2x = 3$
Line D	$y = 4x - 2$
Line E	$2y = 2x - 1$

Two of these lines are perpendicular.
Write down the two perpendicular lines.

.....
(Total 3 marks)

4. The straight line L has equation $y = 2x - 5$
Find an equation of the straight line perpendicular to L which passes through $(0, 3)$.

.....
(Total 2 marks)

5. Find an equation of the straight line that is perpendicular to the straight line $x + 2y = 5$ and that passes through the point $(3, 7)$.

.....
(Total 3 marks)

6. A straight line, L , is perpendicular to the line with equation $y = 1 - 3x$
The point with coordinates $(6, 3)$ is on the line L .
Find an equation of the line L .

.....
(Total 3 marks)

7. In the diagram,
A is the point $(-2, 0)$
B is the point $(0, 4)$
C is the point $(5, -1)$

Find an equation of the line that passes through C and is perpendicular to AB.

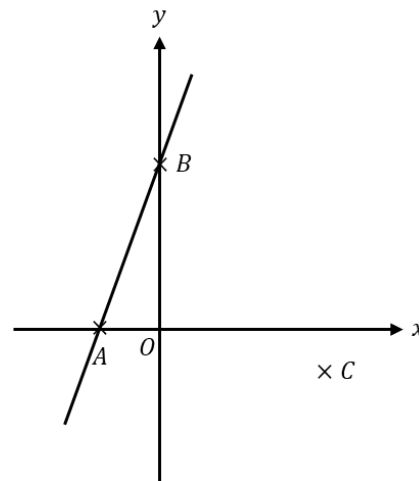

.....
(Total 4 marks)

8. Line A passes through the points $(1, 5)$ and $(5, 7)$
Line B passes through the points $(-1, 7)$ and $(2, 1)$
Show that Line A and Line B are perpendicular.

(Total 4 marks)

Exponential Functions

Things to remember:

- $a^0 = 1$ so the y -intercept of an exponential graph is usually 1.
- The graph of an exponential function should be a smooth curve.
- The x -axis is an asymptote, which means the graph will not intersect it.

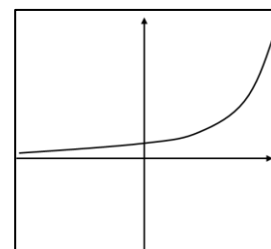

Questions:

1. a) Complete the table of values for $y = 2^x$

x	-2	-1	0	1	2	3	4
y		0.5			4	8	

(2)

- b) Draw the graph of $y = 2^x$ for values of x from -2 to 4

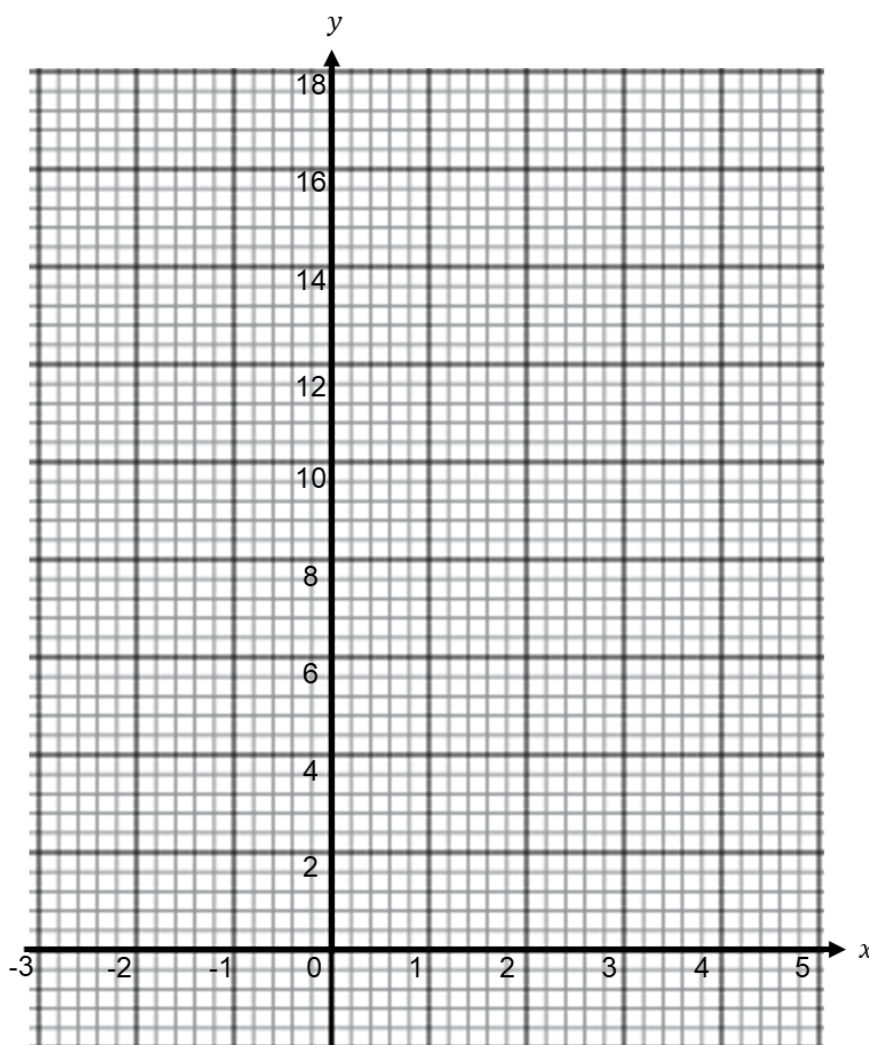

(2)
(Total 4 marks)

2. On the grid, sketch the curve with equation $y = 3^x$
Give the coordinates of any points of intersection with the axes.

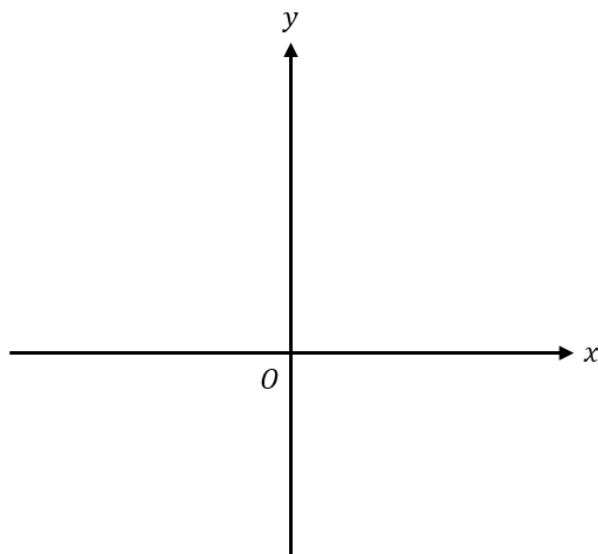

(Total 2 marks)

3. On the grid, sketch the curve with equation $y = 5^x$
Give the coordinates of any points of intersection with the axes.

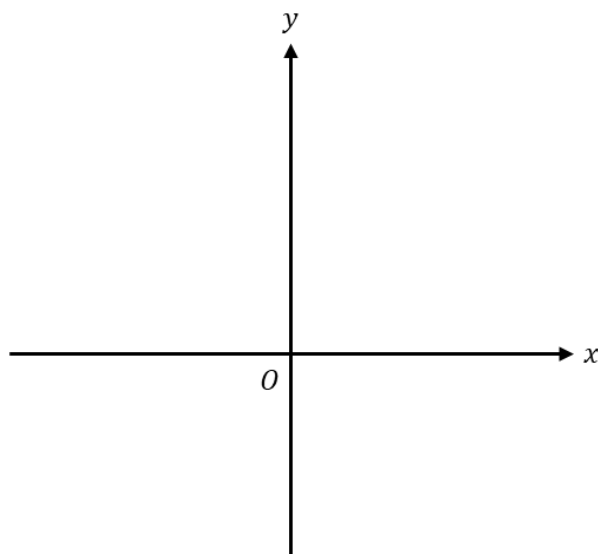

(Total 2 marks)

4. The sketch shows a curve with equation $y = ab^x$ where a and b are constants and $b > 0$

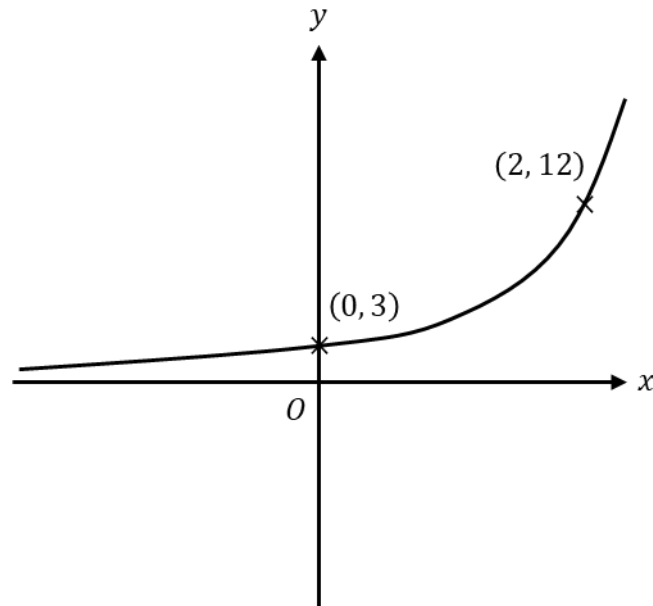

The curve passes through the points $(0, 3)$ and $(2, 12)$
Calculate the value of a and b

$a = \dots\dots\dots$

$b = \dots\dots\dots$

(Total 3 marks)

Types of Graphs

Things to remember:

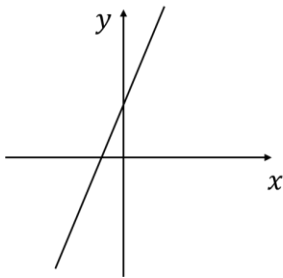

Linear

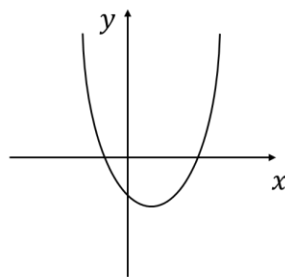

Quadratic

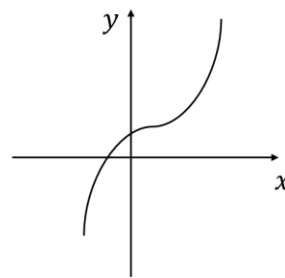

Cubic

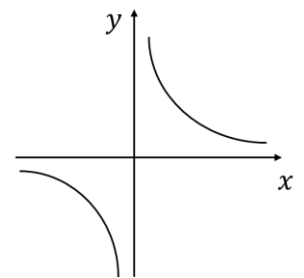

Reciprocal

Questions:

1. Here are four graphs.

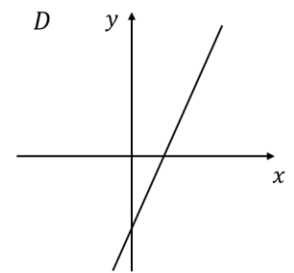
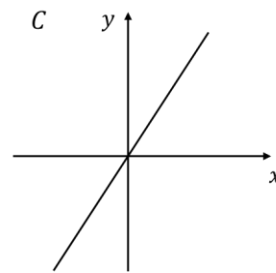
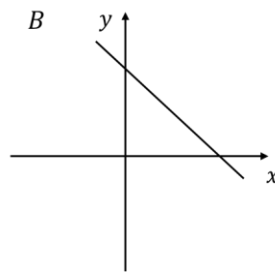
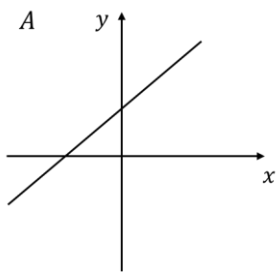

Match each graph to its corresponding equation below.
The first one is done for you.

Graph	Letter
$y = 2x$	C
$y = x + 3$	
$y = 3x - 7$	
$y = 5 - x$	

(Total 3 marks)

2. Here are eight graphs.

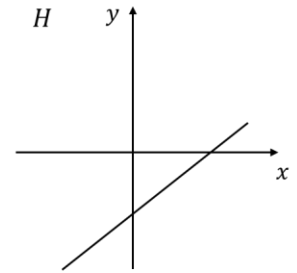
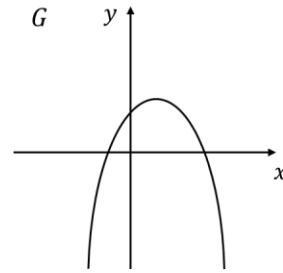
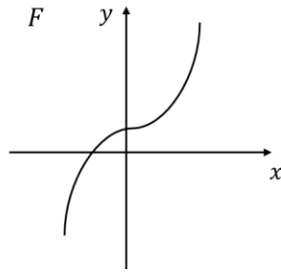
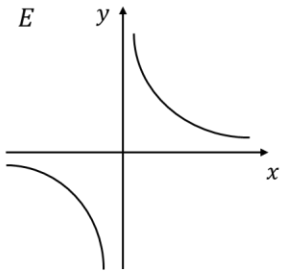
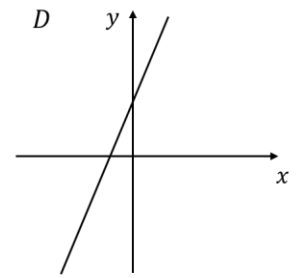
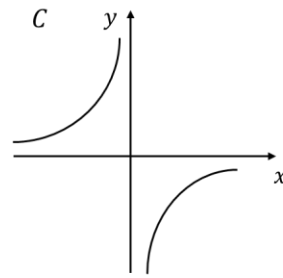
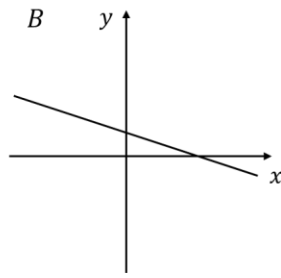
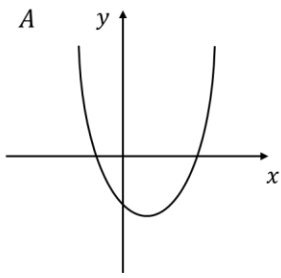

Write down the letter of the graph that could have the equation:

i) $y = 2x + 4$

.....

ii) $y = \frac{2}{x}$

.....

iii) $y = x^2 - 2x - 3$

.....

iv) $y = x^3 + 2$

.....

(Total 4 marks)

3. Here are four graphs.

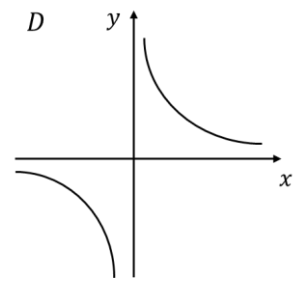
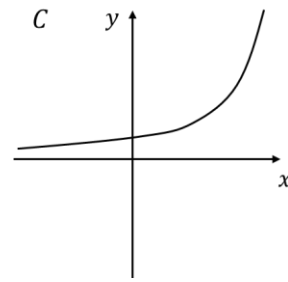
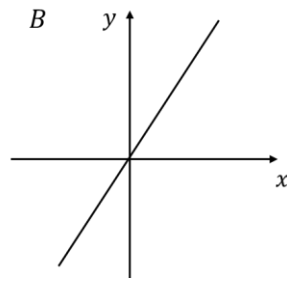
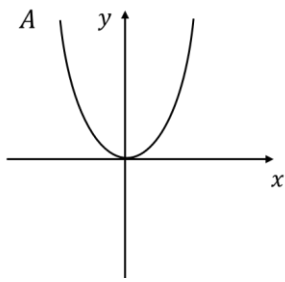

Match each graph to its corresponding equation below.

Graph	Letter
$y = 2x$	
$y = \frac{2}{x}$	
$y = x^2$	
$y = 2^x$	

(Total 4 marks)

Transformations of Graphs

Things to remember:

- $f(x)$ means the function of x
- $-f(x)$ is a reflection in the x -axis
- $f(-x)$ is a reflection in the y -axis
- $f(x - a)$ is a translation by the vector $\begin{pmatrix} a \\ 0 \end{pmatrix}$
- $f(x) + b$ is a translation by the vector $\begin{pmatrix} 0 \\ b \end{pmatrix}$

Questions:

1. The graph of $y = f(x)$ is shown below.

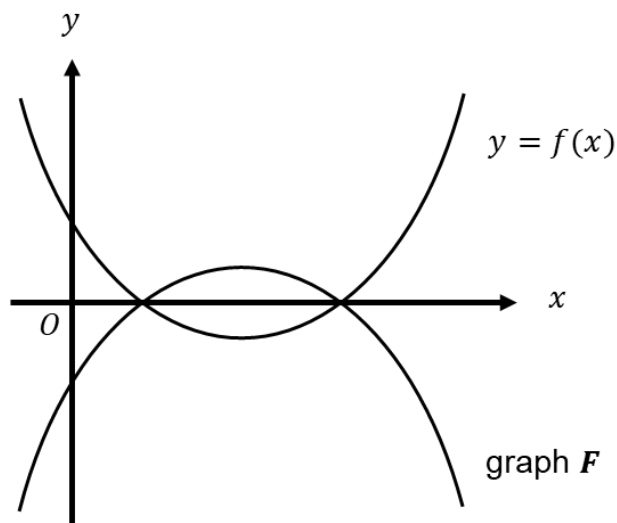

The graph F is the reflection of $y = f(x)$ in the x -axis.
Write down an equation of graph F .

.....
(Total 1 mark)

2. The graph of $y = f(x)$ is shown on the grid.

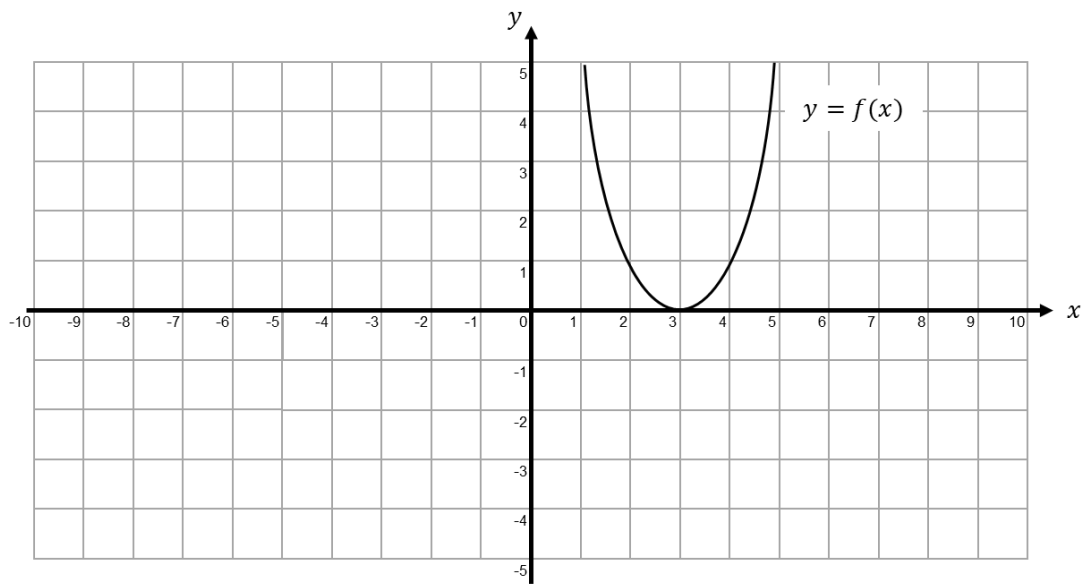

a) On the grid above, sketch the graph of $y = -f(x)$

(2)

The graph of $y = f(x)$ is shown on the grid.

The graph G is a translation of the graph of $y = f(x)$

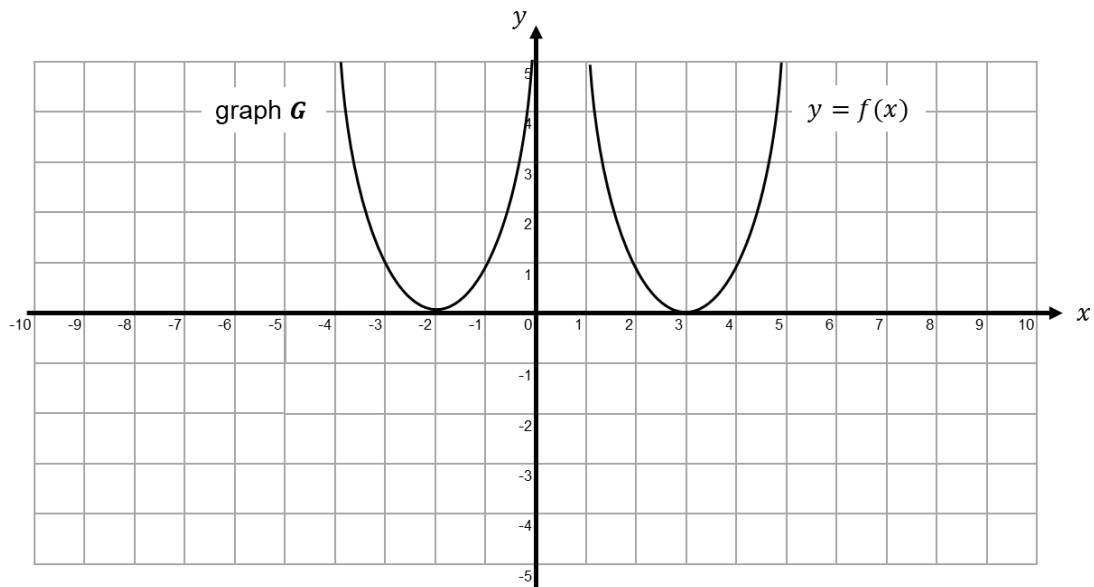

b) Write down the equation of graph G .

.....
(2)
(Total 3 marks)

3. The graph of $y = f(x)$ is shown on both grids below.

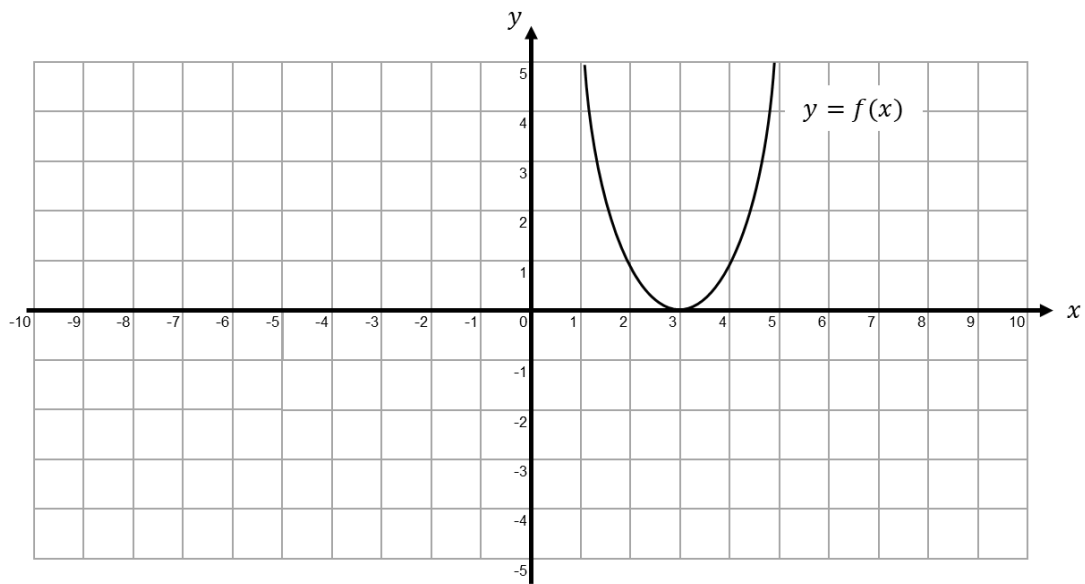

a) On the grid above, sketch the graph of $y = f(-x)$

(1)

b) On this grid below, sketch the graph of $y = -f(x) + 3$

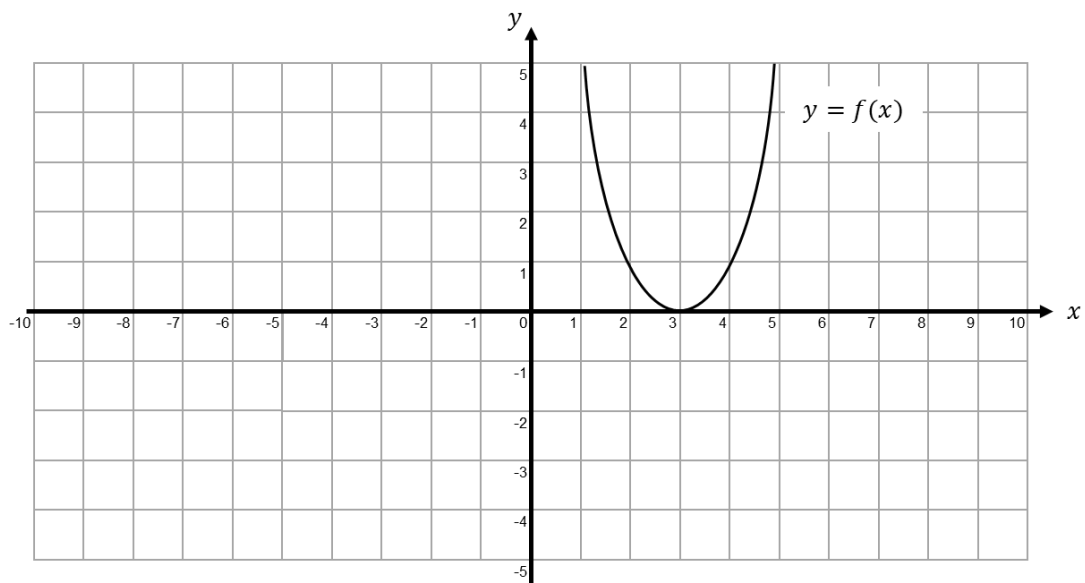

(2)

(Total 3 marks)

Factorising Harder Quadratics

Things to remember:

- Look out for the difference of two squares!
- Check the question carefully before you start – can you take a common factor out of all the terms to make it easier to factorise fully?
- For a quadratic in the form $ax^2 + bx + c = 0$, ac gives the product of the pair of numbers for the ‘tactical split’ and b is the sum.

Questions:

1. Factorise $2p^2 - p - 10$

.....
(Total 2 marks)

2. Solve, by factorising, the equation $8x^2 - 30x - 27 = 0$

.....
(Total 3 marks)

3. Factorise $6t^2 - 7t - 3$

.....
(Total 2 marks)

4. a) Factorise $2t^2 + 5t + 2$

.....
(2)

b) t is a positive whole number.
The expression $2t^2 + 5t + 2$ can never have a value that is a prime number.
Explain why.

.....
.....
.....

(1)
(Total 3 marks)

5. Factorise $8k^2 - 2k - 3$

.....
(Total 2 marks)

6. Solve, by factorising, the equation $6p^2 - 19p + 10 = 0$

.....
(Total 3 marks)

Algebraic Fractions

Things to remember:

- To simplify algebraic fractions, first factorise the numerator and denominator, then cancel common factors.
- Don't forget the usual rules and methods for adding, subtracting, multiplying and dividing fractions.
- To solve algebraic fractions, multiply through by any denominators, then solve as usual.
- Be on the lookout for repeated factors in the denominators!

Questions:

1. Simplify $\frac{x^2+3x}{2x+6}$

.....
(Total 3 marks)

2. Simplify fully $\frac{6m^2+3m}{4m^2-1}$

.....
(Total 3 marks)

3. Simplify $\frac{x^2+2x+1}{x^2+3x+2}$

.....
(Total 3 marks)

4. Simplify fully $\frac{k^2-8k+15}{2k^2-7k-15}$

.....
(Total 3 marks)

5. Simplify fully $\frac{x+3}{4} + \frac{x-5}{3}$

.....
(Total 3 marks)

6. Write $\frac{1}{x+4} + \frac{2}{x-4}$ as a single fraction in its simplest form.

.....
(Total 4 marks)

7. Solve $\frac{5(2x+1)}{3} = 4x + 7$

$x = \dots\dots\dots$
(Total 3 marks)

8. Show that the equation $\frac{5}{x+2} = \frac{4-3x}{x-1}$
can be rearranged to give $3x^2 + 7x - 13 = 0$

(Total 3 marks)

10. Solve the equation $\frac{3}{x+3} - \frac{4}{x-3} = \frac{5x}{x^2-9}$

$x = \dots\dots\dots$
(Total 4 marks)

Quadratic Formula

Things to remember:

- For any quadratic equation in the form $ax^2 + bx + c = 0$, $x = \frac{-b \pm \sqrt{b^2 - 4ac}}{2a}$
- Remember to substitute, simply, split and then solve
- As ever, be careful with negative numbers!

Questions:

1. Solve $5x^2 + x - 11 = 0$
Give your solutions correct to 3 significant figures.

$x = \dots\dots\dots$
(Total 3 marks)

2. Solve $3x^2 - 11x - 13 = 0$
Give your solutions correct to 3 significant figures.

$x = \dots\dots\dots$
(Total 3 marks)

3. Solve $5x^2 = 6x + 3$
Give your solutions correct to 3 significant figures.

$x = \dots\dots\dots$
(Total 3 marks)

4. Solve $x^2 - 4x - 1 = 0$
Give your answers in the form $a \pm \sqrt{b}$

$x = \dots\dots\dots$
(Total 4 marks)

5. Solve $x^2 + 6x - 11 = 0$
Give your answers in the form $a \pm b\sqrt{c}$

$x = \dots\dots\dots$
(Total 4 marks)

6. The diagram shows a six-sided shape formed from two rectangles. All measurements are given in centimetres.

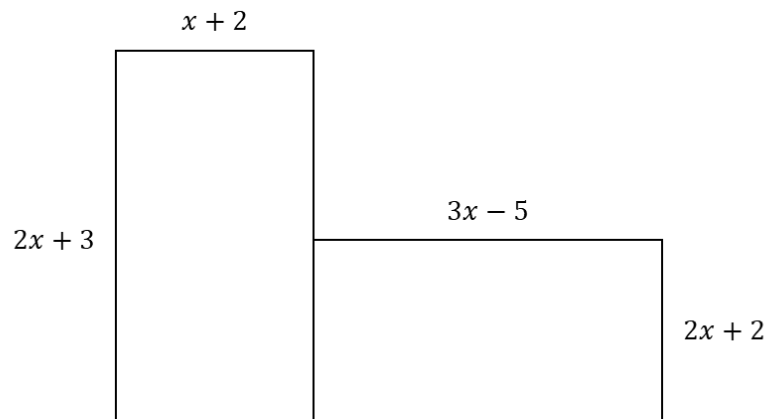

The area of the shape is 35 cm^2

- a) Show that $8x^2 + 3x - 39 = 0$

- b) Find the value of x
Give your answer correct to 3 significant figures.

(2)

$x = \dots\dots\dots$
(3)
(Total 5 marks)

7. The diagram shows a right-angled triangle.
All measurements are given in centimetres.

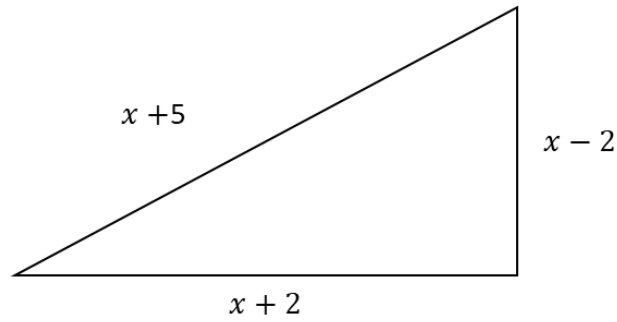

- a) Show that $x^2 - 10x - 17 = 0$

- b) Find the value of x
Give your answer in the form $a \pm \sqrt{b}$

(3)

$x = \dots\dots\dots$

(4)

(Total 7 marks)

Completing the Square

Things to remember:

- To complete the square:
 - Halve the coefficient of x
 - Put in brackets with the x and square the brackets
 - Subtract the half-coefficient squared
 - Don't forget the constant on the end!
 - Simplify
- You may need to factorise a common factor from the x^2 and x terms first
- For $(x - p)^2 + q = 0$, the turning point is (p, q)

Questions:

1. a) Write $x^2 - 6x + 3$ in the form $(x + a)^2 + b$ where a and b are integers.

.....
(2)

b) Hence, or otherwise, write down the coordinates of the turning point of the graph of $y = x^2 - 6x + 3$

.....
(1)

(Total 3 marks)

2. a) Write $x^2 + 8x - 4$ in the form $(x + a)^2 + b$ where a and b are integers.

.....
(2)

b) Hence, or otherwise, write down the coordinates of the turning point of the graph of $y = x^2 + 8x - 4$

.....
(1)

(Total 3 marks)

3. By completing the square, solve $x^2 + 10x - 2 = 0$
Give your answers in surd form.

.....
(Total 5 marks)

4. By completing the square, solve $x^2 - 5x + 1 = 0$
Give your answers in surd form.

.....
(Total 5 marks)

5. a) Write $2x^2 + 16x + 26$ in the form $a(x + b)^2 + c$ where a , b and c are integers.

..... (3)

b) Hence, or otherwise, write down the coordinates of the turning point of the graph of $y = 2x^2 + 16x + 26$

..... (1)

(Total 4 marks)

6. a) Write $3x^2 - 6x + 6$ in the form $a(x + b)^2 + c$ where a , b and c are integers.

..... (3)

b) Hence, or otherwise, write down the coordinates of the turning point of the graph of $y = 3x^2 - 6x + 6$

..... (1)

(Total 4 marks)

Inequality Regions

Things to remember:

- Use a table of values if you need to help you draw the linear graphs
- Use a solid line for \geq or \leq , and a dotted line for $>$ or $<$
- Test a coordinate ($(0, 0)$ is easiest) to work out which side of the line to shade

Questions:

1. Write down the three inequalities that define the shaded region.

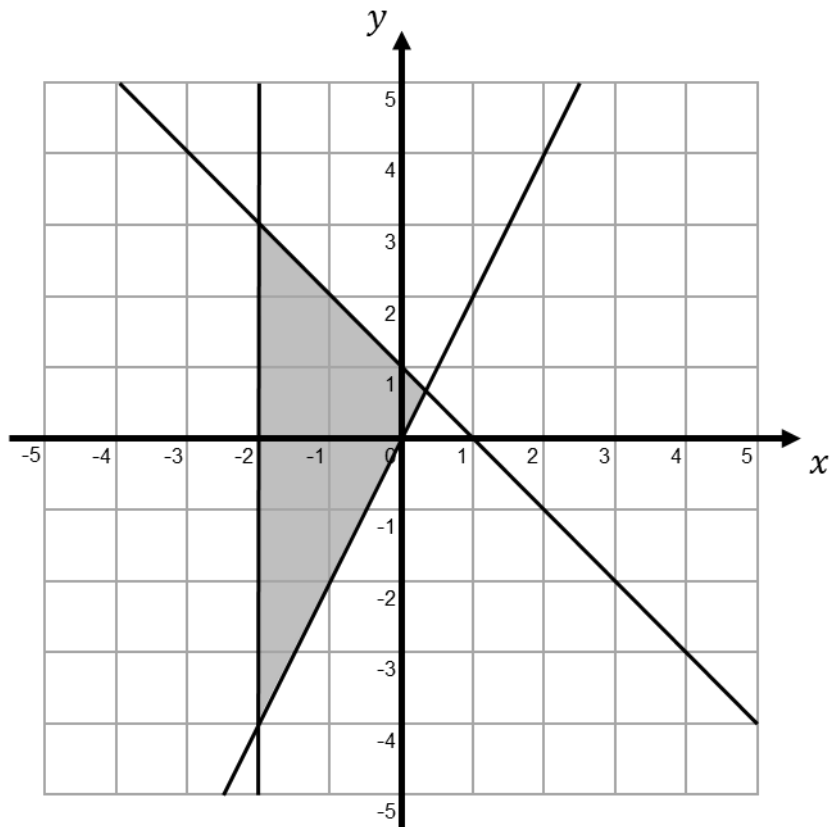

.....

.....

.....

(Total 4 marks)

2. On the grid shade the region that satisfies all these inequalities

$$x < 4$$

$$y > -2$$

$$y \leq 2x - 1$$

Label the region *R*.

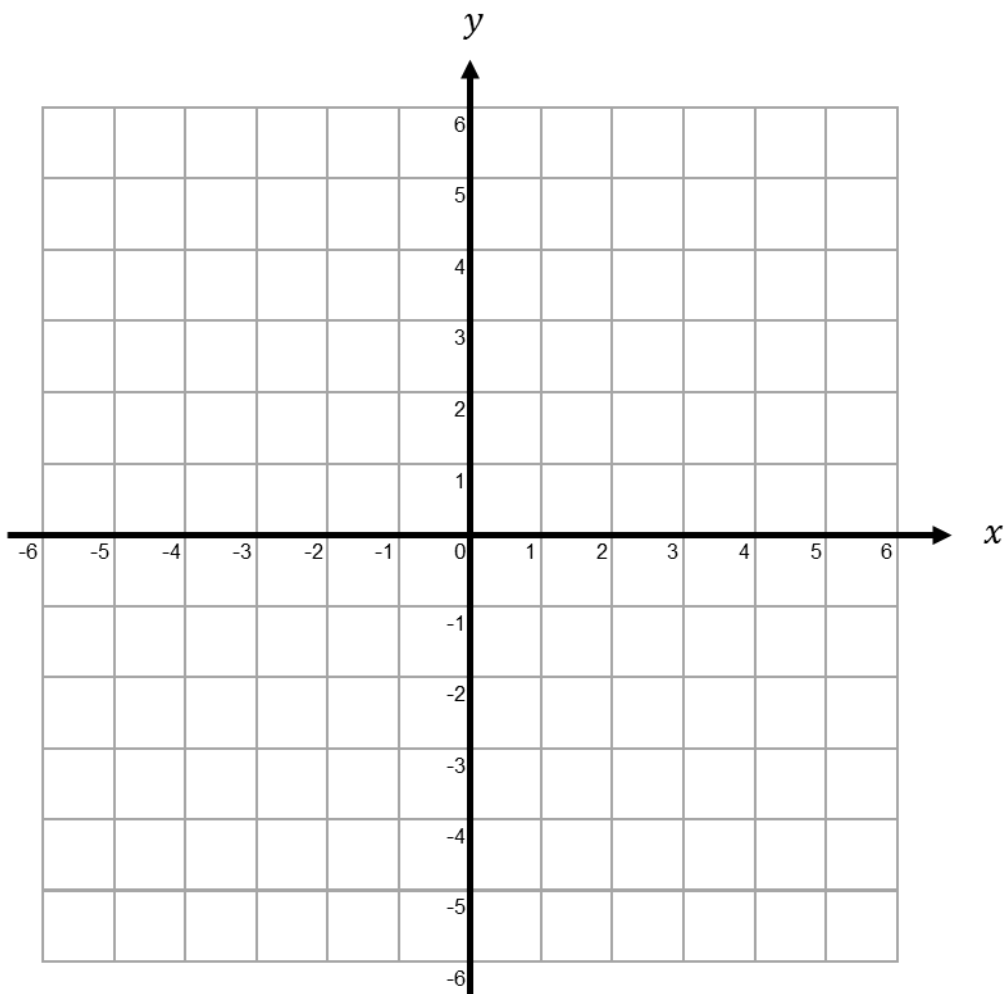

(Total 3 marks)

3. On the grid shade the region that satisfies all these inequalities

$$x + y < 4$$

$$y > 2x + 1$$

$$y > -1$$

Label the region *R*.

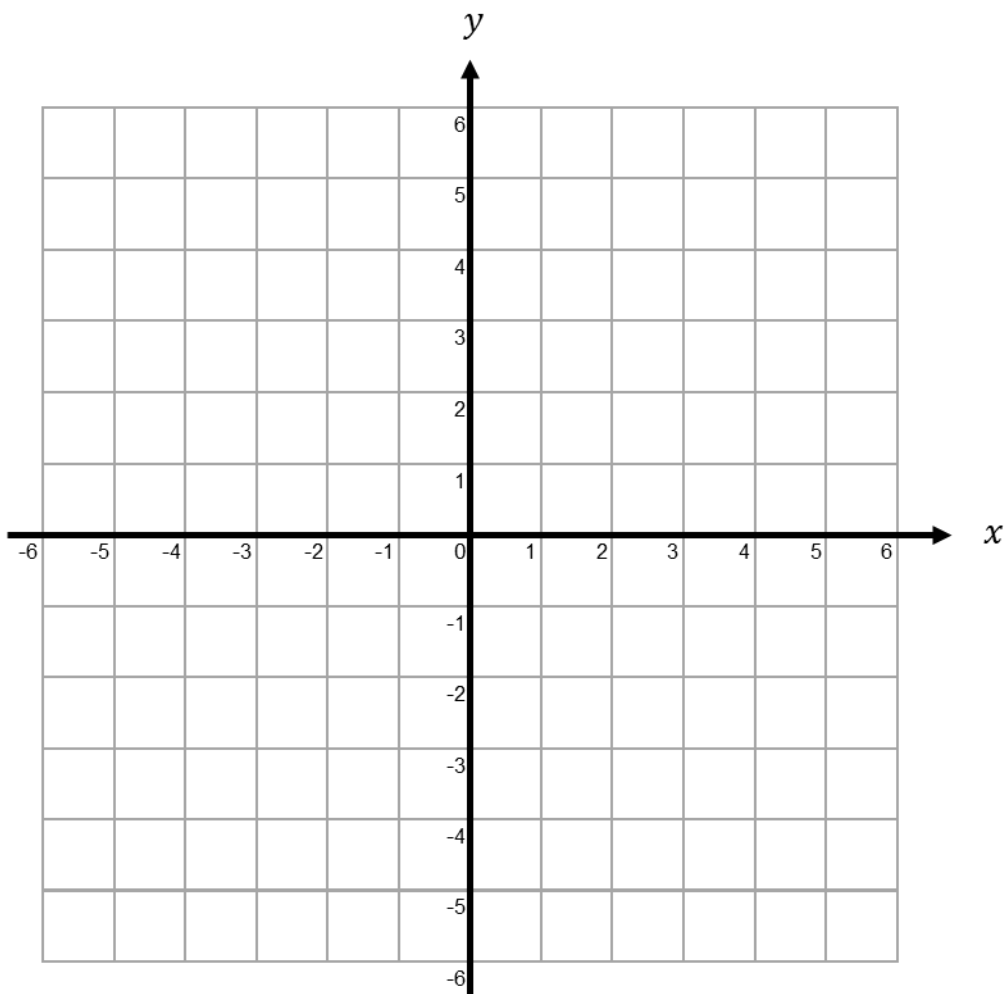

(Total 3 marks)

4. The lines $y = x - 1$ and $x + y = 9$ are drawn on the grid.

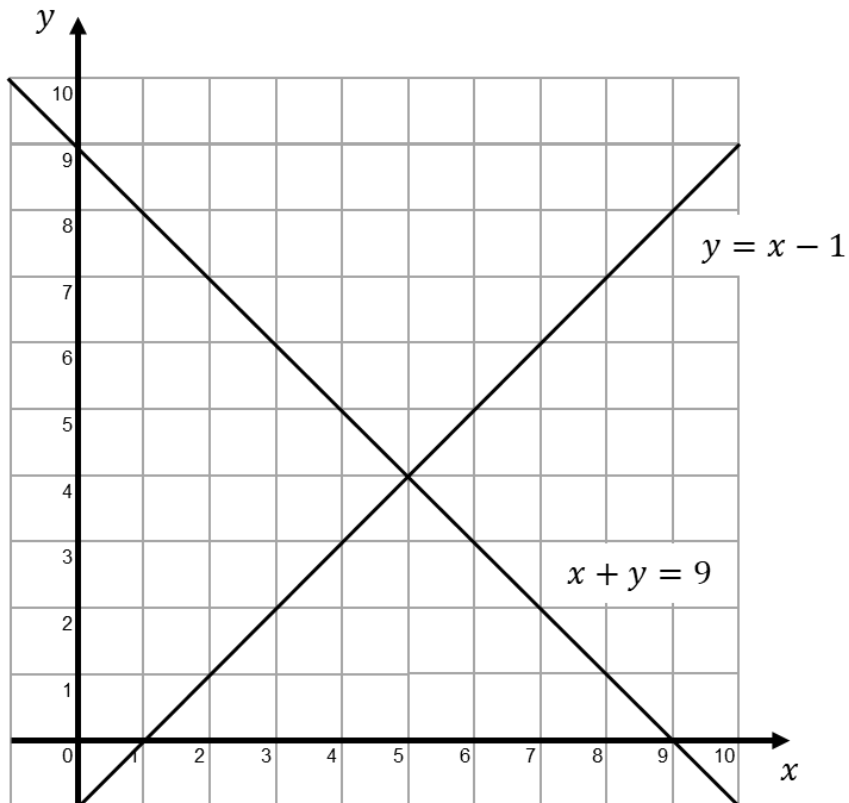

On the grid, mark with a cross (x) each of the points with integer coordinates that are in the region defined by

$$y \geq x - 1$$

$$x + y \leq 9$$

$$x \geq 4$$

(Total for Question is 3 marks)

Circle Theorems

Things to remember:

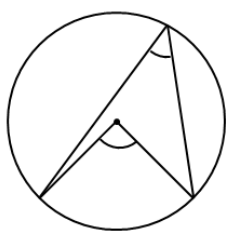

The angle at the centre is twice the angle at the circumference.

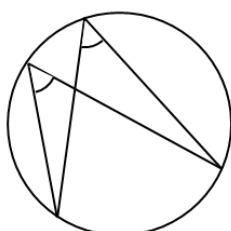

Angles subtended by the same arc are equal.

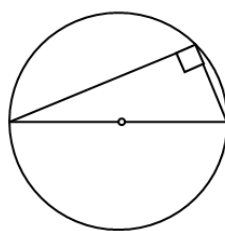

The angle in a semi-circle is 90° .

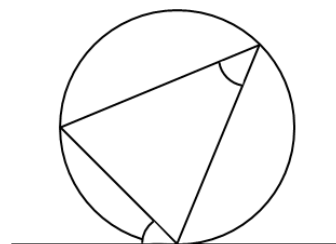

Angles in alternate segments are equal.

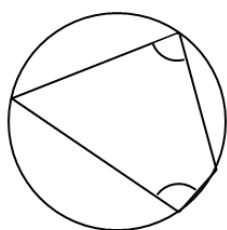

Opposite angles in a cyclic quadrilateral sum to 180° .

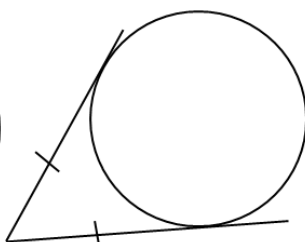

Tangents from a point are equal.

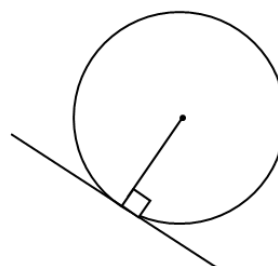

A tangent is perpendicular to a radius.

Questions:

1. A is a point on the circumference of the circle, centre O .
 AB is a tangent to the circle.

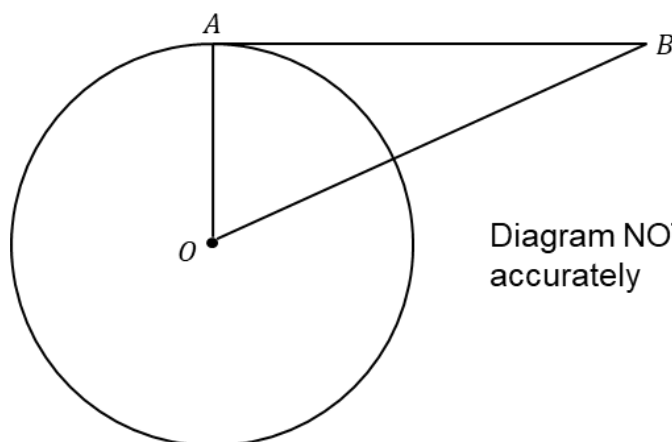

Diagram NOT drawn accurately

- i) Write down the size of angle OAB .

- ii) Give a reason for your answer.

.....

(Total 2 marks)

2. P , Q and R are points on the circumference of a circle, centre O .
 Angle $POR = 110^\circ$

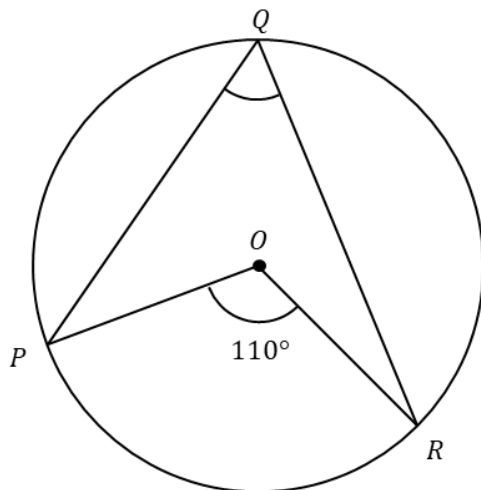

Diagram NOT drawn accurately

- i) Work out the size of angle PQR .

.....^o

- ii) Give a reason for your answer.

.....

(Total 2 marks)

3. K , L and M are points on the circumference of a circle, centre O .
 KM is a diameter of the circle.

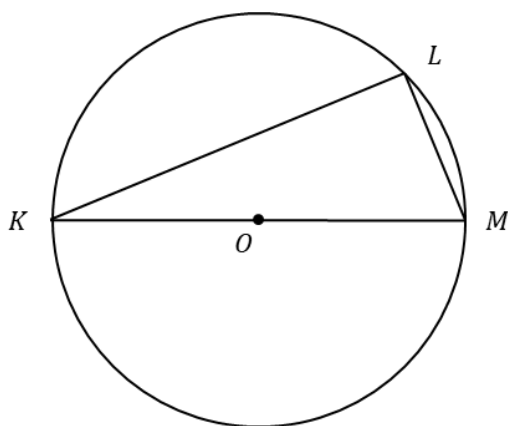

Diagram NOT drawn accurately

- i) Work out the size of angle KLM .

.....^o

- ii) Give a reason for your answer.

.....

(Total 2 marks)

4. In the diagram, A , B , C and D are points on the circumference of a circle, centre O .

Angle $ABC = 50^\circ$

Angle $AOC = x^\circ$

Angle $ADC = y^\circ$

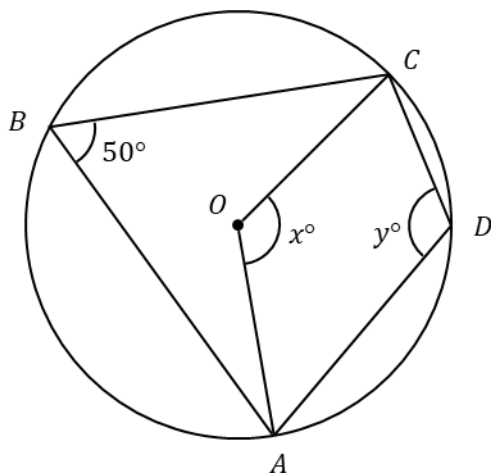

Diagram NOT drawn accurately

a) i) Work out the value of x .

.....^o

ii) Give a reason for your answer.

.....

.....

(2)

b) i) Work out the value of y .

.....^o

ii) Give a reason for your answer.

.....

.....

(2)

(Total 4 marks)

5. P and Q are points on the circumference of a circle, centre O .
 PR and QR are tangents to the circle.
Angle $PRQ = 55^\circ$

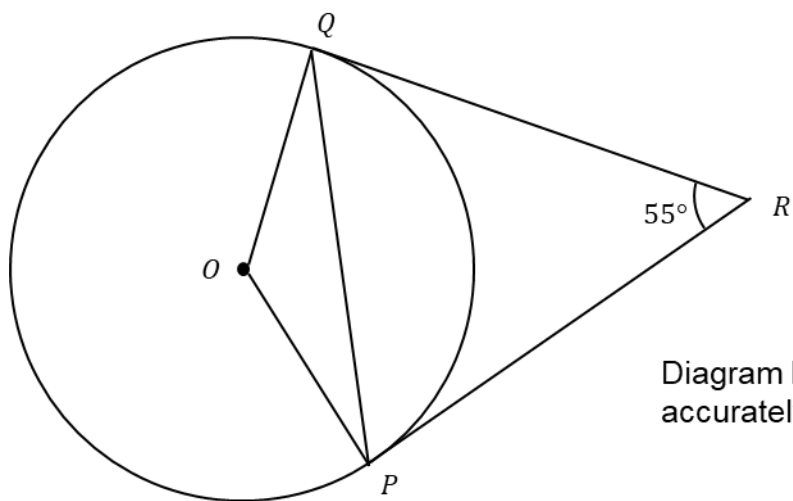

Diagram NOT drawn accurately

Find the size of angle OPQ .
Give reasons for each stage of your working.

.....
(Total 4 marks)

6. A , B and C are points on the circumference of a circle, centre O .
 DCE is a tangent to the circle.

Angle $ABO = 35^\circ$
 Angle $BCE = 50^\circ$

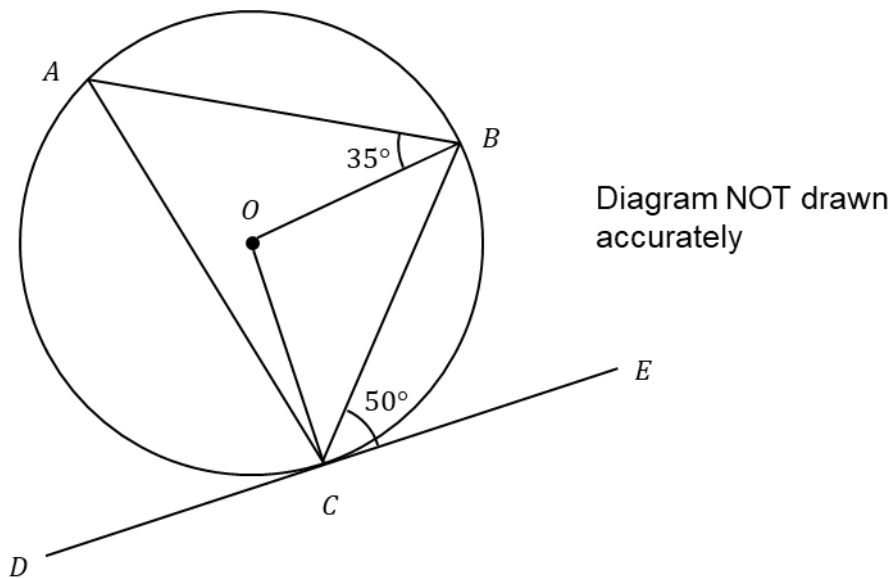

Find the size of angle ACO .
 Give reasons for each stage of your working.

.....^o
 (Total 4 marks)

Enlargement

Things to remember:

- A fractional scale factor means the image will be that fraction of the object's original size
- A negative scale factor means the image will be a different orientation and on the opposite side of the centre of enlargement to the object
- Pick a vertex at a time to transform using the given scale factor
- Remember that when describing an enlargement, you need to state the scale factor and the centre of enlargement

Questions:

1. On the grid, enlarge the triangle by scale factor -2 centre O

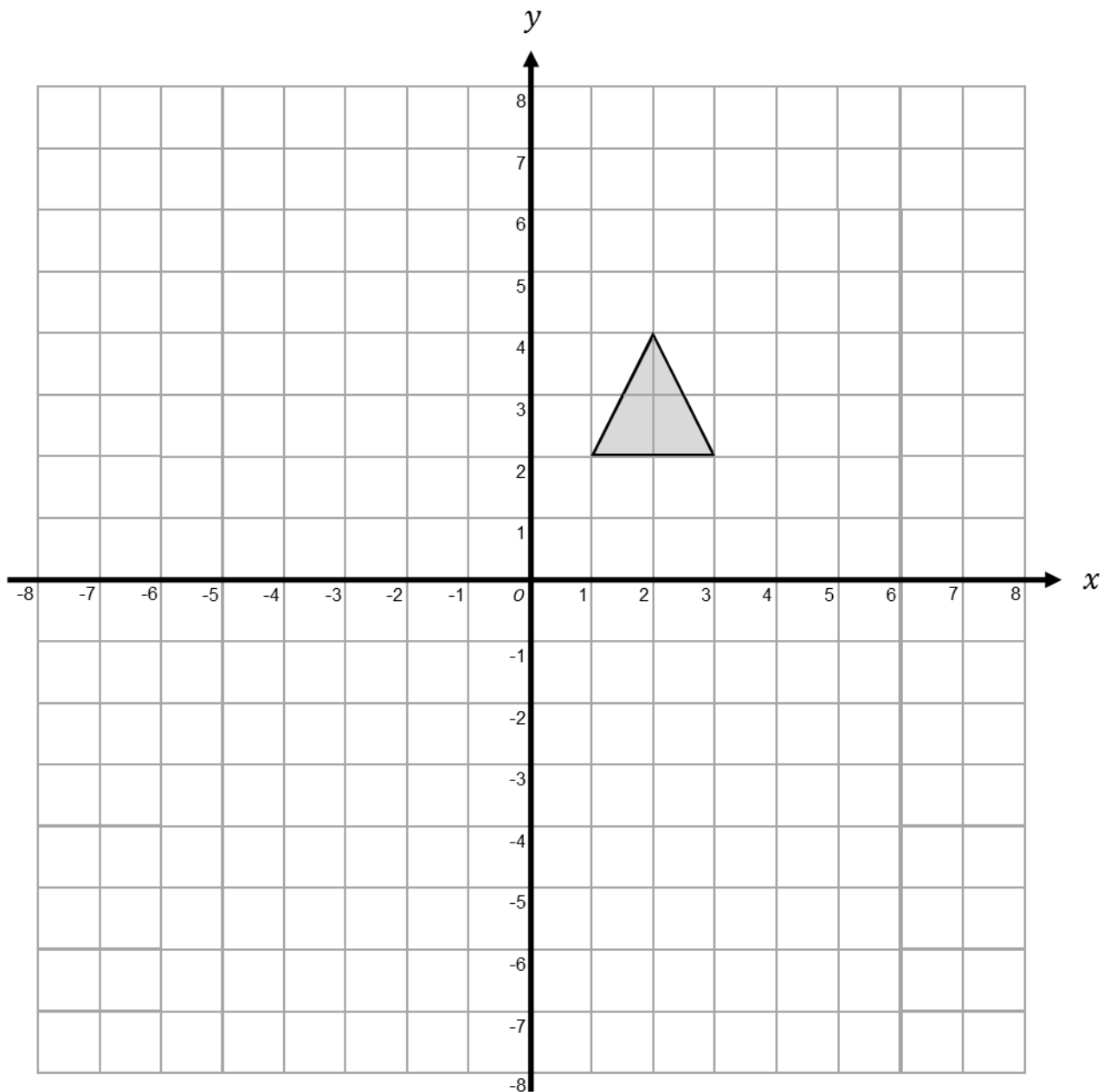

(Total 2 marks)

2. On the grid, enlarge the shape by scale factor -3 centre $(-5, -4)$

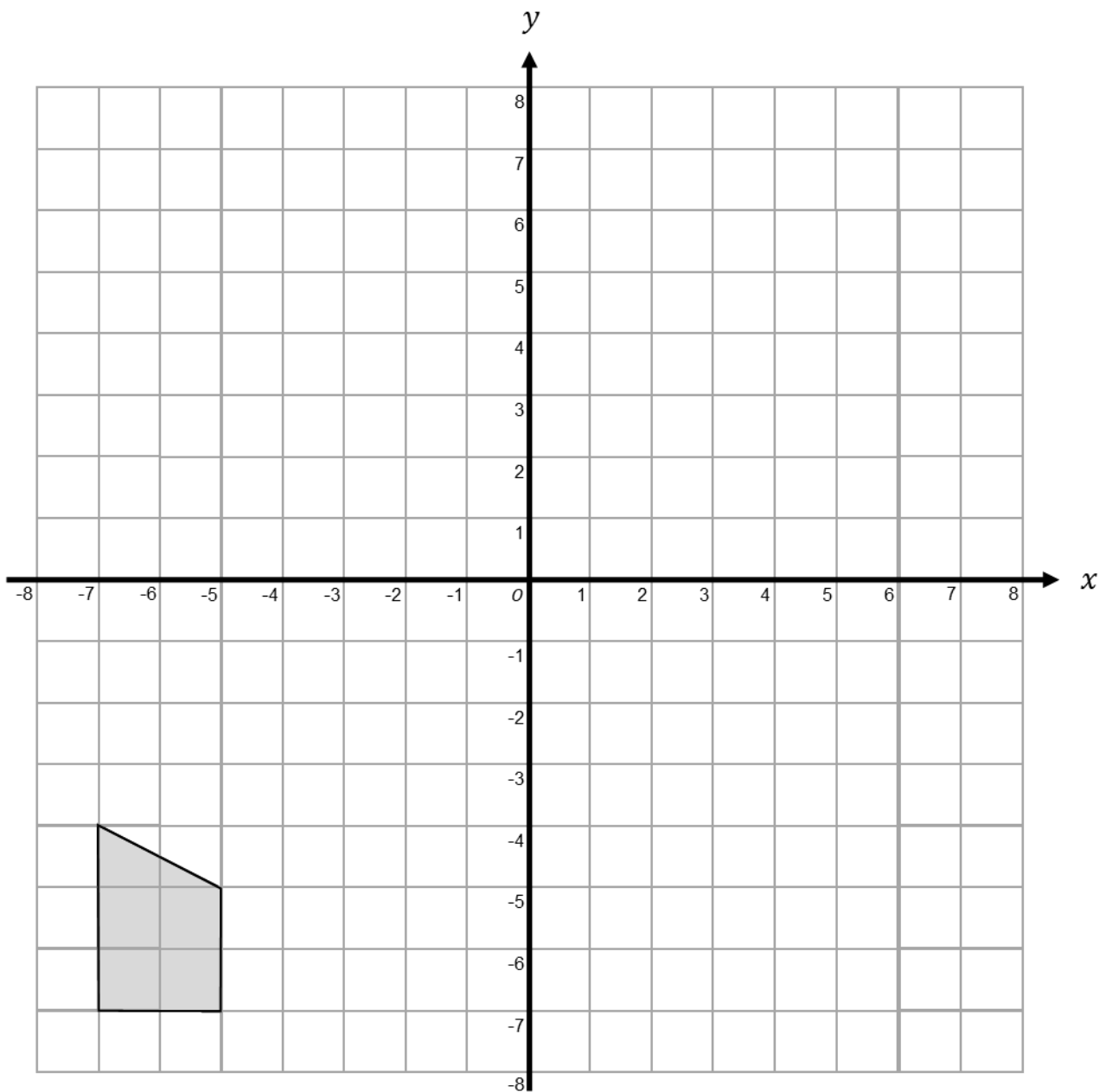

(Total 2 marks)

3. On the grid, enlarge the triangle by scale factor $-\frac{1}{2}$, centre O

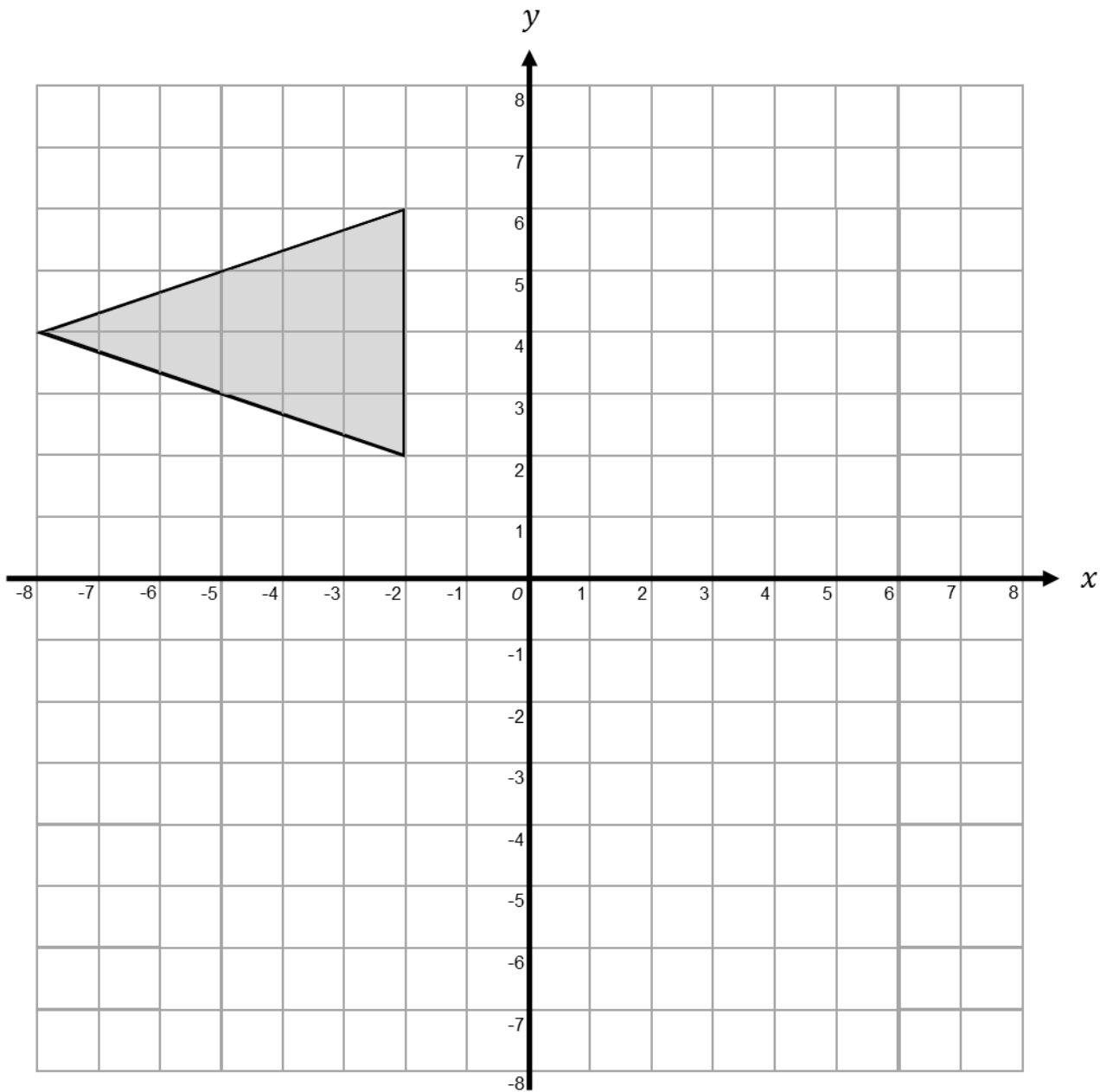

(Total 2 marks)

4. Describe fully the single transformation which maps triangle A onto triangle B .

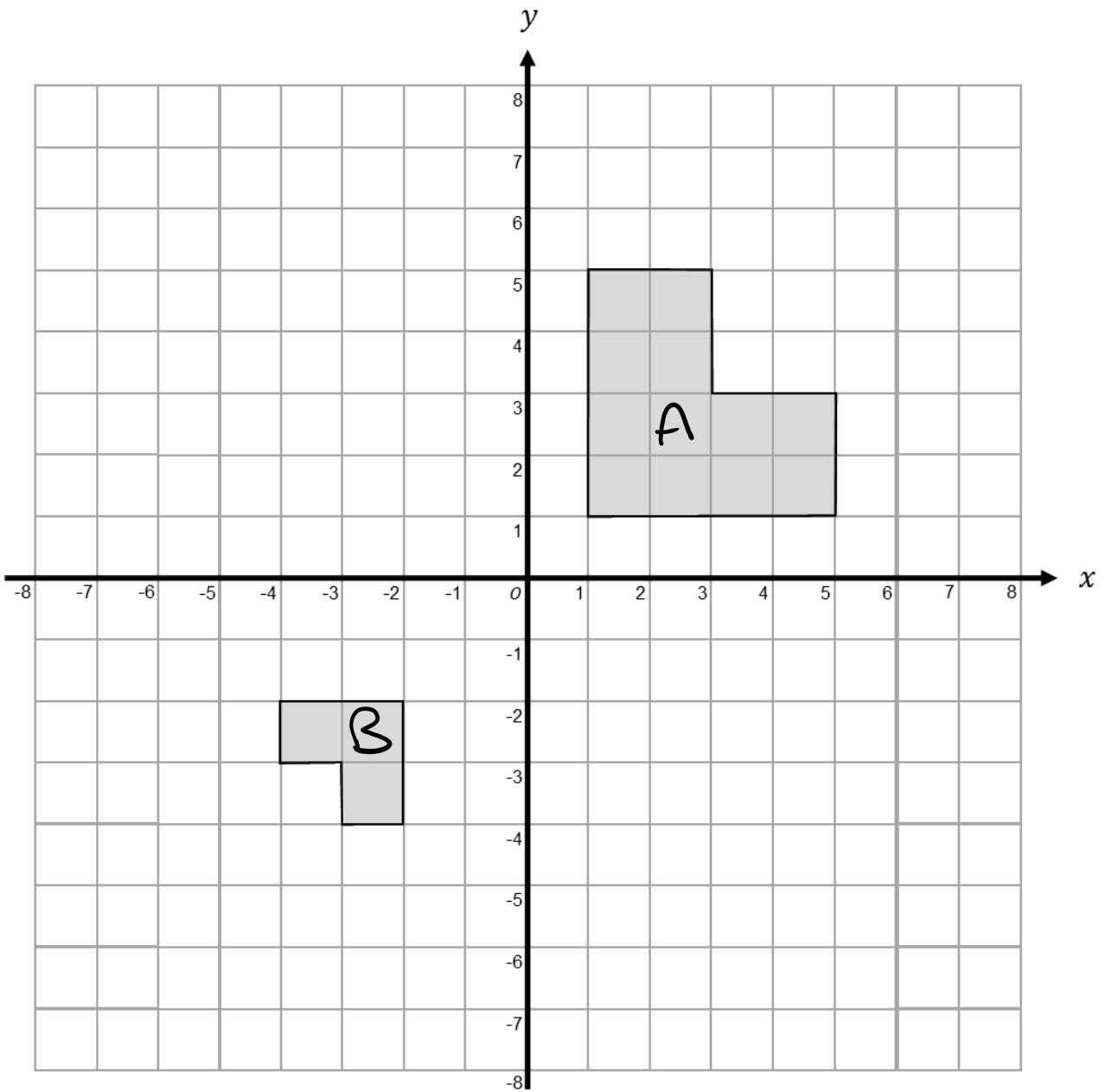

.....

.....

.....

(Total 2 marks)

Column Vectors

Things to remember:

- For any column vector $\begin{pmatrix} x \\ y \end{pmatrix}$, x denotes the horizontal movement and y denotes the vertical movement
- Column vectors can be added, subtracted and multiplied by a scalar as below:

$$\begin{pmatrix} a \\ b \end{pmatrix} + \begin{pmatrix} c \\ d \end{pmatrix} = \begin{pmatrix} a + c \\ b + d \end{pmatrix}$$

$$\begin{pmatrix} a \\ b \end{pmatrix} - \begin{pmatrix} c \\ d \end{pmatrix} = \begin{pmatrix} a - c \\ b - d \end{pmatrix}$$

$$k \begin{pmatrix} a \\ b \end{pmatrix} = \begin{pmatrix} ka \\ kb \end{pmatrix}$$

Questions:

1. The vector c is drawn on the grid.
From the point P , draw the vector $4c$

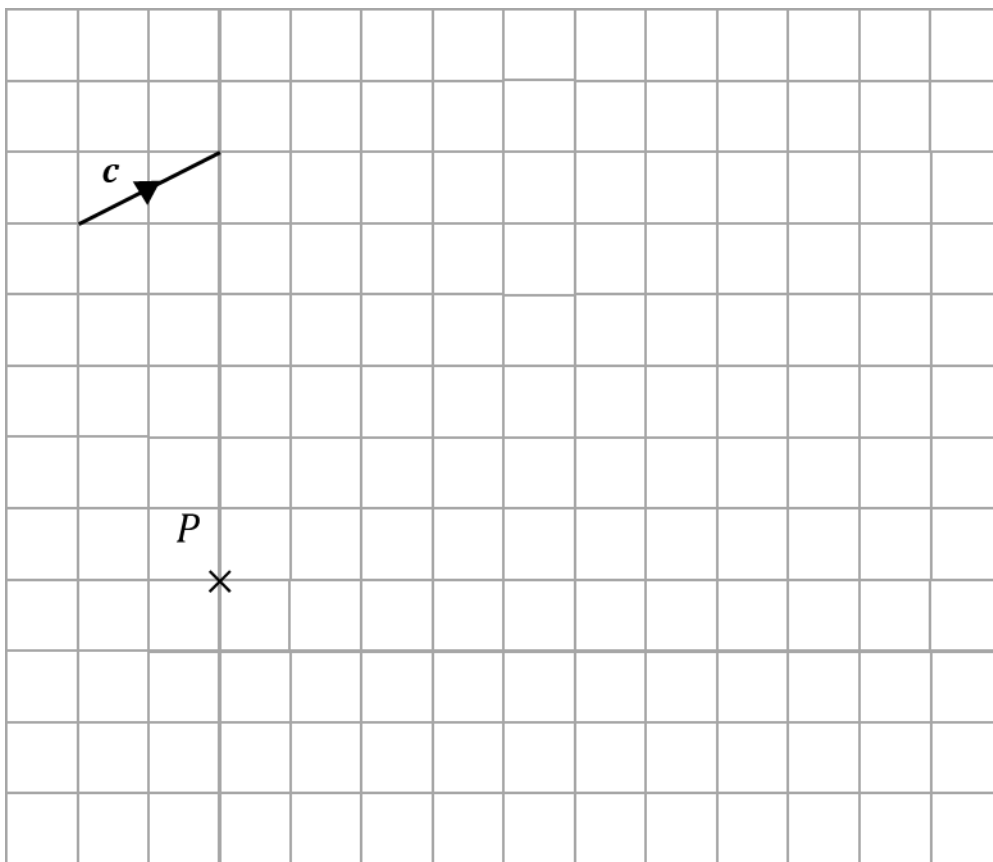

(Total 1 mark)

2. $\mathbf{a} = \begin{pmatrix} 2 \\ 5 \end{pmatrix}$ and $\mathbf{b} = \begin{pmatrix} -3 \\ 4 \end{pmatrix}$

Write down, as a column vector

a) $\mathbf{a} + \mathbf{b}$

.....
(1)

b) $2\mathbf{a} - \mathbf{b}$

.....
(2)
(Total 3 marks)

3. $\mathbf{p} = \begin{pmatrix} 1 \\ 6 \end{pmatrix}$ and $\mathbf{q} = \begin{pmatrix} 4 \\ -5 \end{pmatrix}$

Write down, as a column vector

a) $\mathbf{p} - \mathbf{q}$

.....
(1)

b) $3\mathbf{p} + 2\mathbf{q}$

.....
(2)
(Total 3 marks)

4. A is the point $(2, 4)$ and B is the point $(-3, 6)$

a) Write down as a column vector \overrightarrow{AB}

.....
(1)

C is the point $(-4, 7)$ and D is the point $(2, -1)$

b) Write down as a column vector \overrightarrow{CD}

.....
(1)
(Total 2 marks)

Sine and Cosine Rules

Things to remember:

In any triangle ABC where a , b and c are the lengths of the sides:

- Sine rule: $\frac{a}{\sin A} = \frac{b}{\sin B} = \frac{c}{\sin C}$
- Cosine rule: $a^2 = b^2 + c^2 - 2bc \cos A$
- Area of a triangle = $\frac{1}{2} a b \sin C$

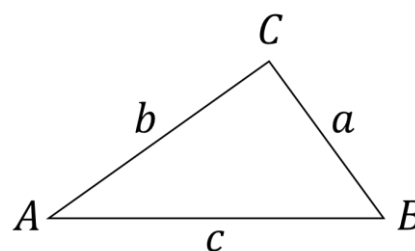

Questions:

1. The diagram shows a triangle ABC

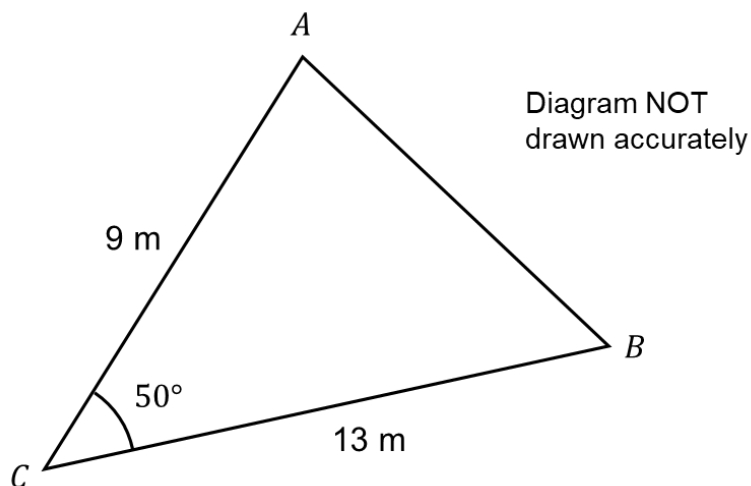

- a) Calculate the area of the triangle ABC .
Give your answer correct to 3 significant figures.

..... m²
(2)

- b) Calculate the length of AB .
Give your answer correct to 3 significant figures.

..... m
(3)
(Total 5 marks)

2. ABC is a triangle.

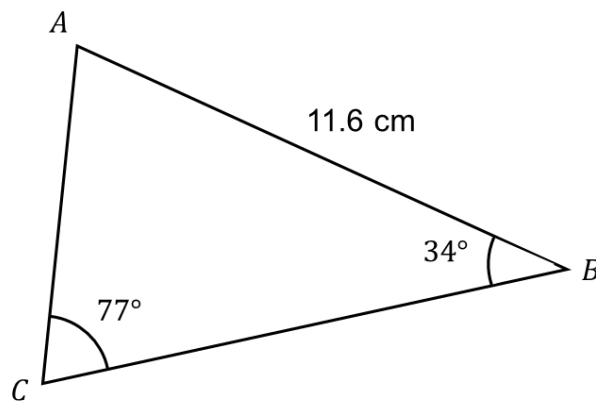
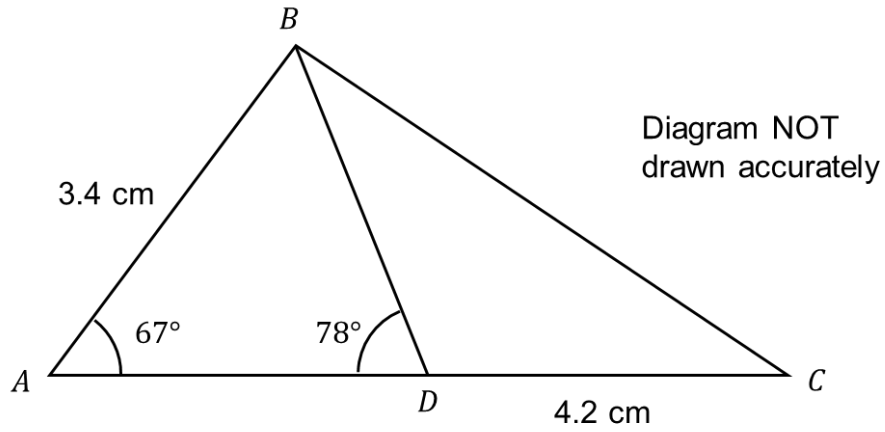

Diagram NOT
drawn accurately

Calculate the area of triangle ABC .
Give your answer correct to 3 significant figures.

..... cm^2
(Total 5 marks)

3. ABC is a triangle.
 D is a point on AC .



Work out the length of BC .
Give your answer correct to 3 significant figures.

..... cm
(Total 5 marks)

4. $ABCD$ is a quadrilateral.

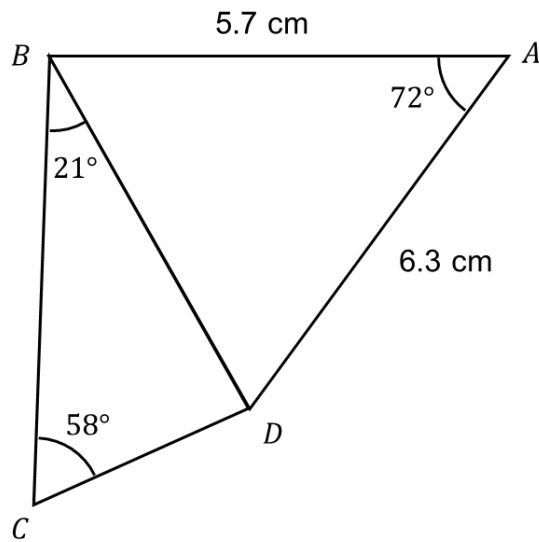
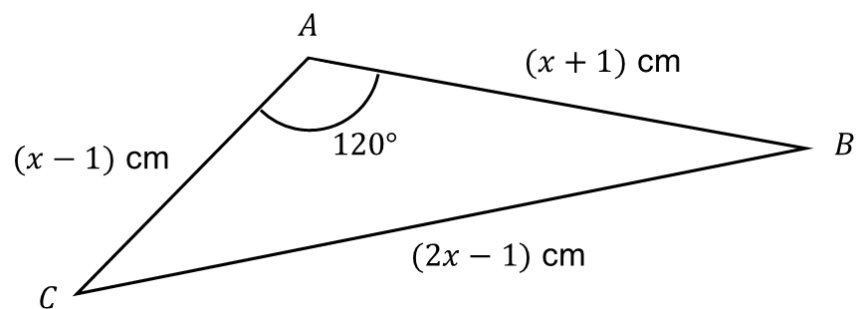

Diagram NOT
drawn accurately

Work out the length of DC .
Give your answer correct to 3 significant figures.

..... cm
(Total 6 marks)

5. The diagram shows triangle ABC .



The area of triangle ABC is $k\sqrt{3}$ cm^2
Find the exact value of k

$k = \dots\dots\dots$
(Total 7 marks)

Arcs and Sectors

Things to remember:

- A sector is a fraction of a circle and an arc is a fraction of a circumference
- Area of sector = $\frac{\theta}{360} \times \pi r^2$
- Length of arc = $\frac{\theta}{360} \times \pi d$

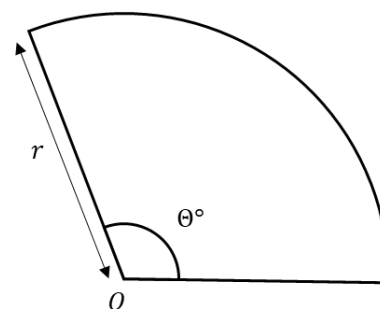

Questions:

1. The diagram shows a sector, centre O .
The radius of the circle is 4 cm.
The angle of the sector is 120° .
Calculate the area of the sector.
Give your answer correct to 3 significant figures.

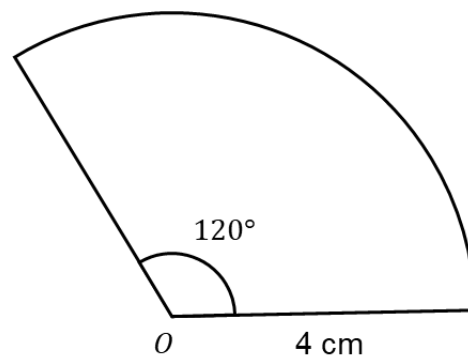

..... cm²
(Total 2 marks)

2. AOB is a sector of a circle, centre O and radius 7.2 cm
The angle of the sector is 54°
Find the length of the arc AB
Give your answer in terms of π

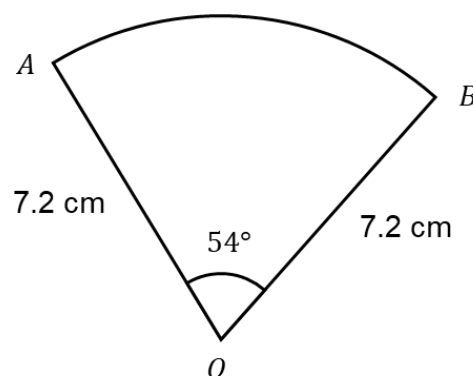

..... cm
(Total 2 marks)

3. AOB is a sector of a circle, centre O and radius 9.2 cm
 The angle of the sector is 96°
 Find the perimeter of the sector.
 Give your answer correct to 3 significant figures.

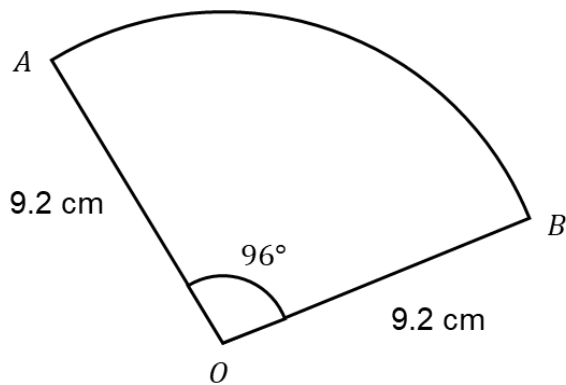

..... cm
 (Total 3 marks)

4. AOB is a sector of a circle, centre O and radius 11 cm
 The length of arc AB is 16 cm
 Find the area of the sector.

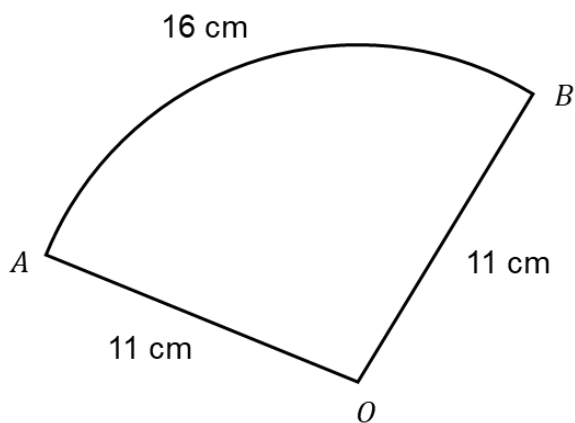

..... cm²
 (Total 4 marks)

5. PQR is an arc of a circle centre O with radius 6.7 cm
 PR is a chord of the circle.
Angle $POR = 35^\circ$
Calculate the area of the shaded region.
Give your answer to 4 significant figures.

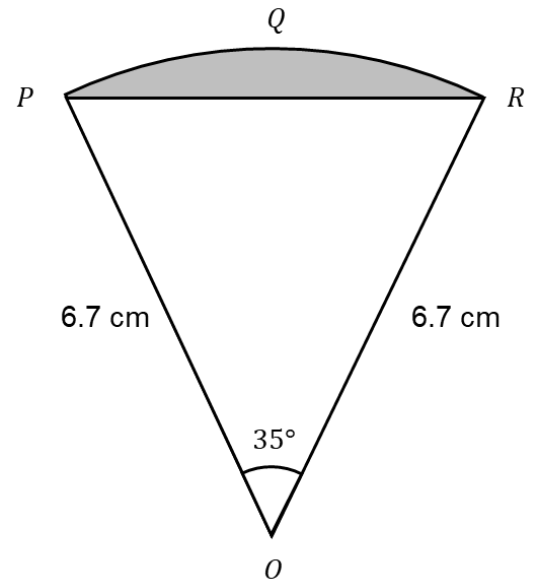

..... cm²
(Total 5 marks)

Length, Area and Volume Scale Factors

Things to remember:

- When a shape is enlarged, the image is similar to the original shape. It is the same shape but a different size
- In similar shapes, the corresponding lengths are in the same ratio. This fact can be used to calculate lengths
- If the length scale factor is k , the area scale factor is k^2
- If the length scale factor is k , the volume scale factor is k^3

Questions:

1. The two triangles ABC and PQR are mathematically similar.

Angle $A =$ angle P
Angle $B =$ angle Q

$AB = 9$ cm
 $AC = 21$ cm
 $PQ = 6$ cm
 $QR = 18$ cm

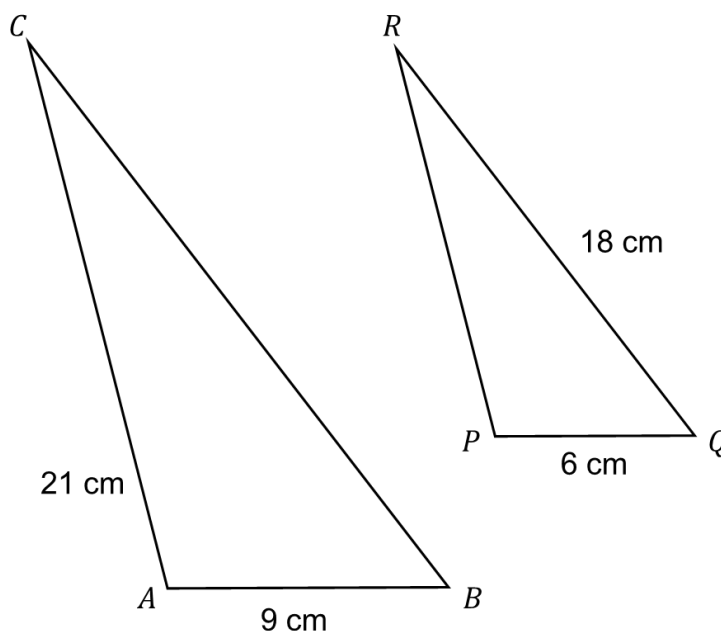

- a) Calculate the length of PR .

..... cm
(2)

- b) Calculate the length of BC .

..... cm
(2)
(Total 4 marks)

2. $AB : AC = 1 : 3$

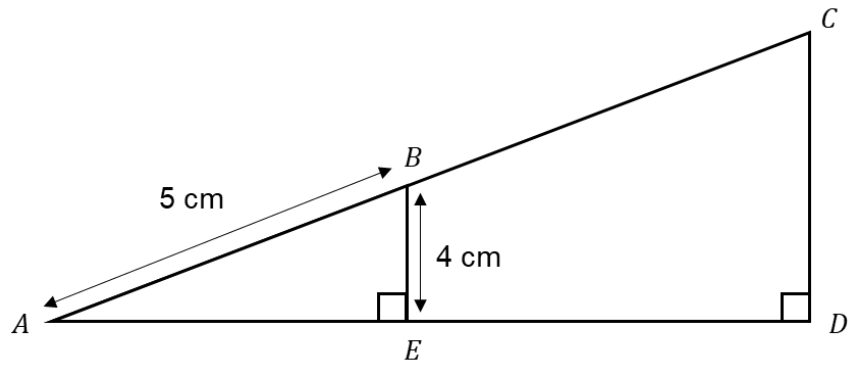

a) Calculate the length of CD

..... cm
(2)

b) Calculate the length of BC

..... cm
(2)

(Total 4 marks)

3. These two clocks are similar.

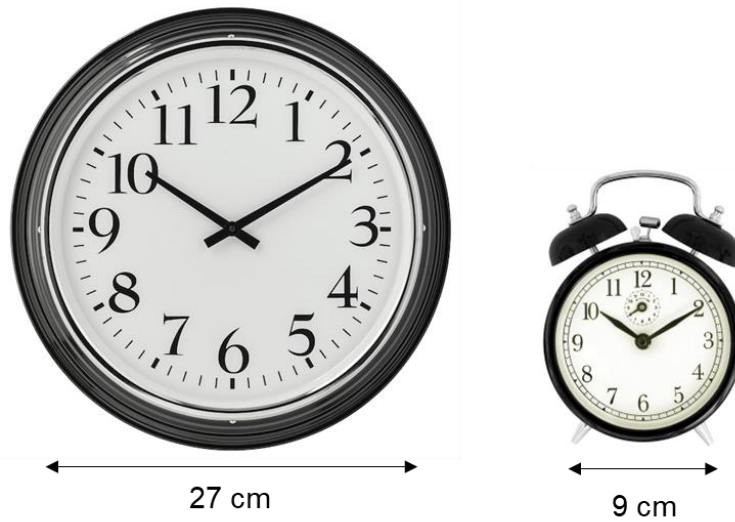

The area of the small clock face is approximately 28.3 cm^2
Calculate the area of the face of the larger clock.

..... cm^2
(Total 3 marks)

4. The two cylinders, A and B , are mathematically similar.
 The height of cylinder B is twice the height of cylinder A .
 The total surface area of cylinder A is 160 cm^2 .
 Calculate the total surface area of cylinder B .

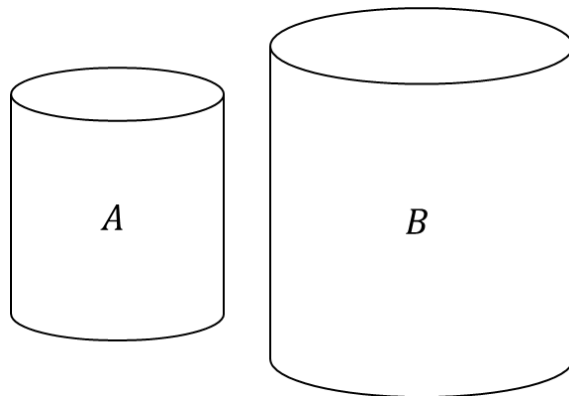

..... cm^2
 (Total 3 marks)

5. Two cones, P and Q , are mathematically similar.
 The total surface area of cone P is 18 cm^2 .
 The total surface area of cone Q is 72 cm^2 .
 The volume of cone P is 12 cm^3 .
 Work out the volume of cone Q .

..... cm^3
 (Total 3 marks)

6. X and Y are two geometrically similar solid shapes.
 The total surface area of shape X is 450 cm^2
 The total surface area of shape Y is 800 cm^2
 The volume of shape X is 1350 cm^3
 Calculate the volume of shape Y

..... cm^3
 (Total 3 marks)

7. A soft drink is sold in three different sized bottles that are mathematically similar.

The table below shows information about the bottles.

Complete the table.

	Height	Capacity
Small	12 cm	300 ml
Medium	15 cm	
Large		1750 ml



(Total 5 marks)

Volumes of Frustums

Things to remember:

- A frustum is a cone or a pyramid with the top chopped off
- You may need to use what you know about similar shapes
- The formulae for a cone will be given in an exam if needed so you do not need to remember them!

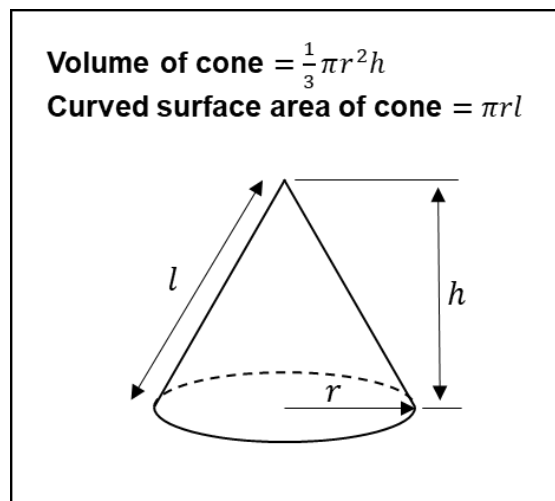

Questions:

1. A frustum is made by removing a small pyramid from a similar larger one.

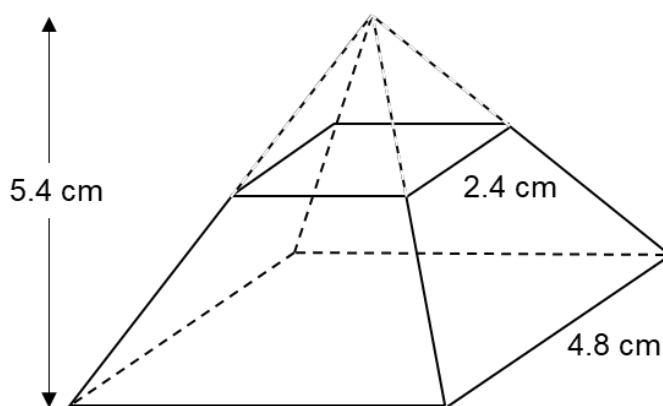

The base of the large pyramid is a square with side length 4.8 cm
The base of the small pyramid is a square with side length 2.4 cm
The height of the large pyramid is 5.4 cm
Work out the volume of the frustum.

..... cm³
(Total 4 marks)

2. A frustrum is made by removing a small cone from a similar large cone.
 The height of the small cone is 6 cm.
 The height of the large cone is 12 cm.
 The diameter of the base of the large cone is 9 cm.
 Work out the volume of the frustrum.
 Give your answer correct to 3 significant figures.

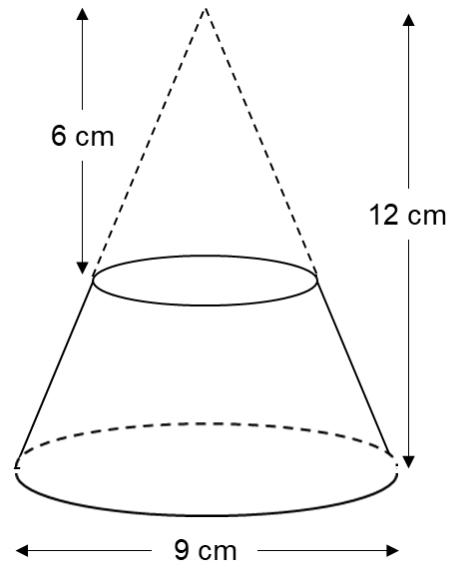

..... cm³
 (Total 4 marks)

3. Rhiannon is making a solid metal sculpture.
 Rhiannon has a metal cone with base radius of 30 cm and perpendicular height 60 cm.
 She removes a smaller cone from the top of the cone to leave a frustrum of height 40 cm.
 The density of the metal is 8 g/cm³
 Find the mass of the sculpture.
 Give your answer correct to the nearest kilogram.

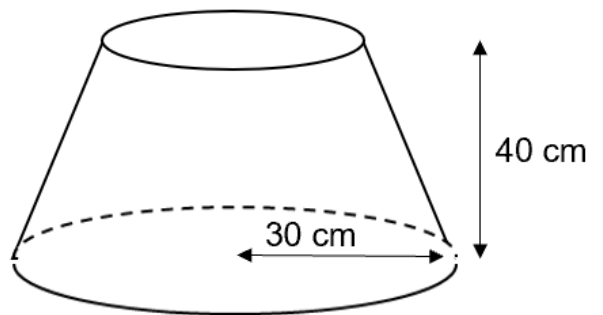

..... g
 (Total 5 marks)

Cumulative Frequency and Box Plots

Things to remember:

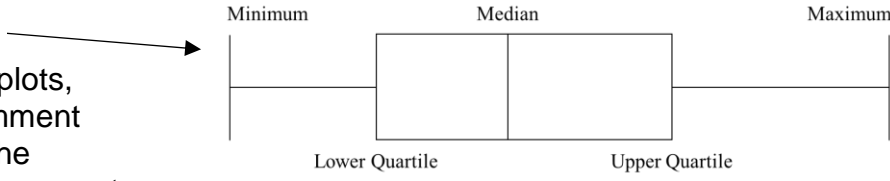
- Use a running total for a cumulative frequency table
- Plot coordinates at the end of each group
- Join up the coordinates with a smooth curve
- To find the median, find the value half-way down the cumulative frequency, draw across to the line and then vertically down to find the value – always show these working lines
- To find the interquartile range, find the upper quartile and the lower quartile and subtract them
- To draw a box plot... 
- When comparing box plots, use the median to comment on the averages and the interquartile range to comment on the spread
- Make sure your comparison is in the context of the question

Questions:

1. A company tested 100 lightbulbs. The table shows information about the number of hours that the lightbulbs lasted.

Time (t hours)	Frequency
$100 \leq t < 150$	12
$150 \leq t < 200$	21
$200 \leq t < 250$	36
$250 \leq t < 300$	23
$300 \leq t < 350$	8

- a) Complete the cumulative frequency table for this information.

Time (t hours)	Cumulative Frequency
$100 \leq t < 150$	
$100 \leq t < 200$	
$100 \leq t < 250$	
$100 \leq t < 300$	
$100 \leq t < 350$	

(1)

b) On the grid, draw a cumulative frequency graph for your completed table.

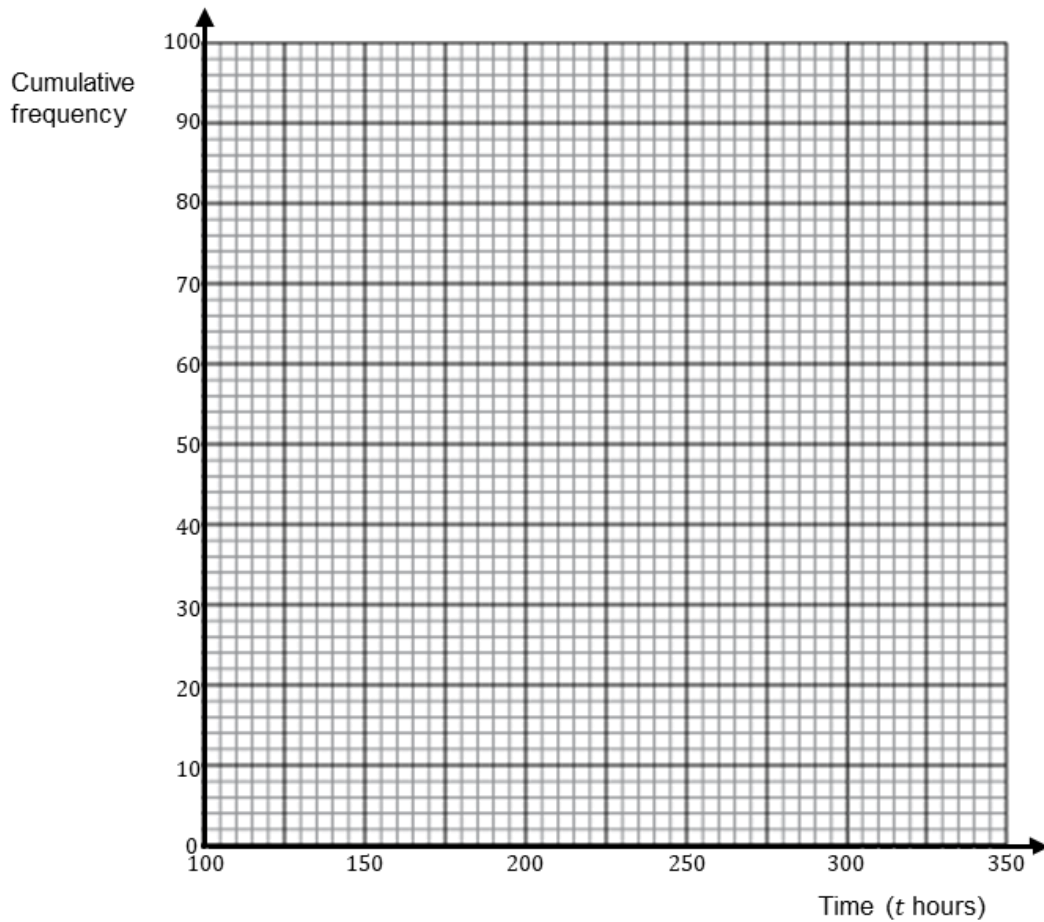

c) Use your completed graph to find an estimate for the median time. You must state the units of your answer. (2)

.....

(2)
(Total 5 marks)

2. A medical practice took 100 calls one day. The table gives information about the time (t minutes) it took the receptionist to answer each call.

a) Complete the cumulative frequency table.

Time (t minutes)	Frequency	Cumulative Frequency
$0 < t \leq 2$	16	
$2 < t \leq 4$	34	
$4 < t \leq 6$	32	
$6 < t \leq 8$	14	
$8 < t \leq 10$	4	

(1)

b) On the grid, draw a cumulative frequency graph for your table.

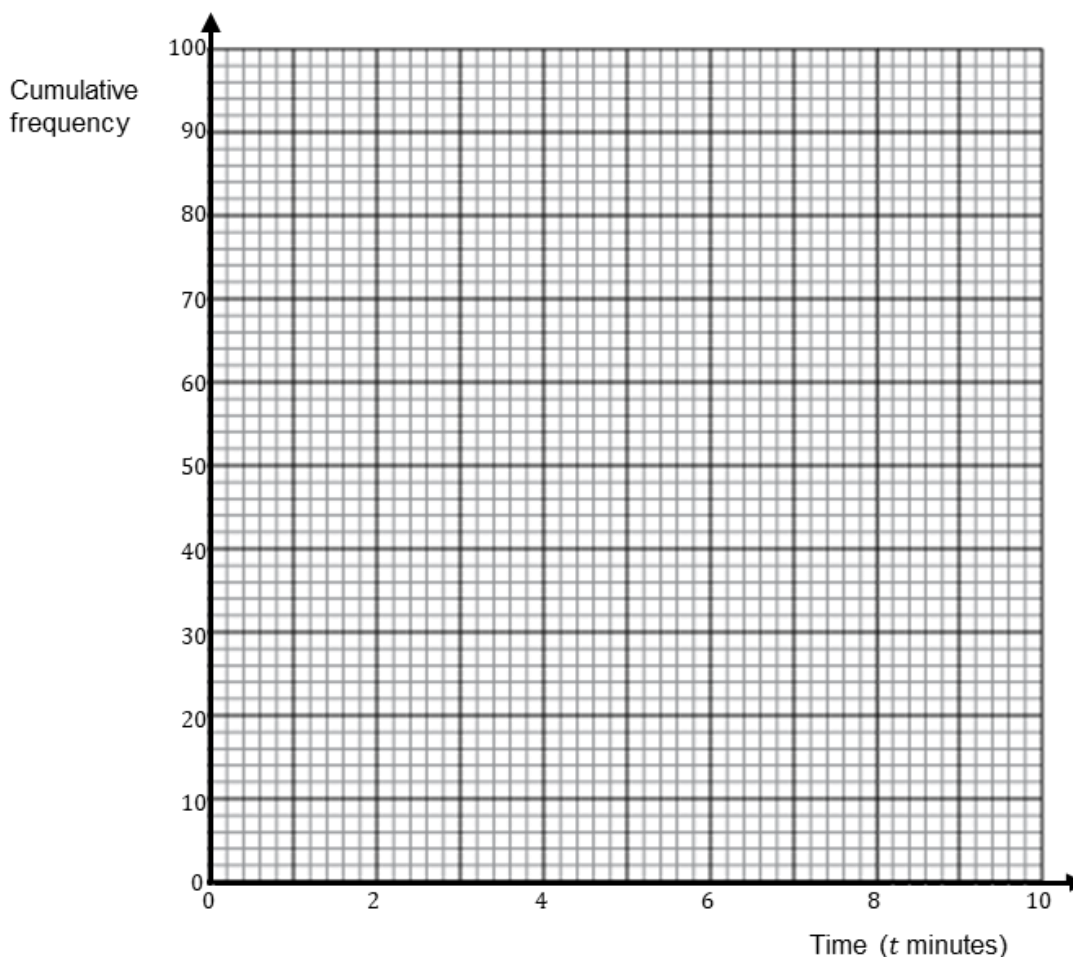

(2)

c) Use your graph to find an estimate for the number of calls the operator took more than 3 minutes and 30 seconds to answer.

.....

(2)

(Total 5 marks)

3. 200 year 10 students took a maths test. The cumulative frequency graph gives information about their marks.

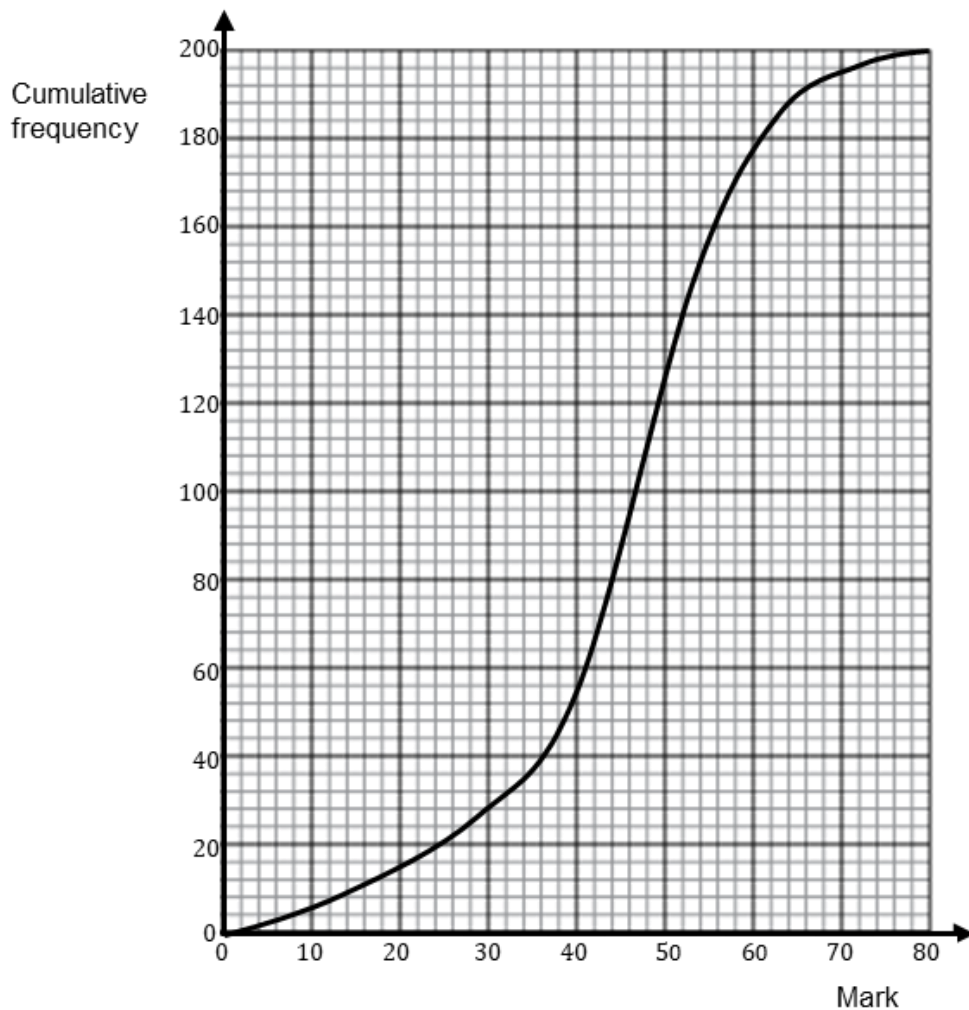

The lowest mark scored in the test was 4.
 The highest mark scored in the test was 80.
 Use this information and the cumulative frequency graph to draw a box plot showing information about the students' marks.

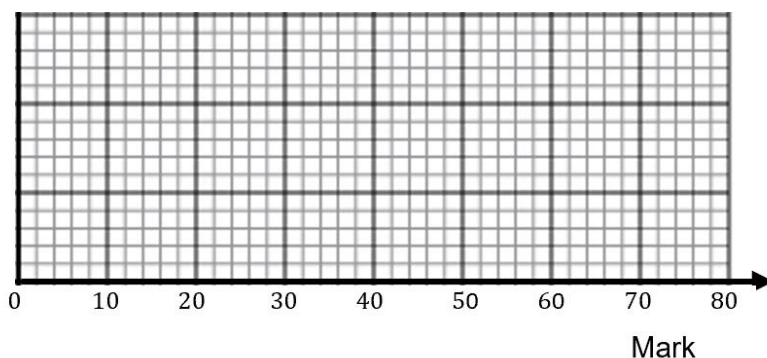

(Total 3 marks)

4. Melanie went to the train station on Friday and she recorded the number of minutes that each train was delayed. She used her results to work out the information in this table.

	Minutes
Shortest delay	0
Lower quartile	2
Median	8
Upper quartile	18
Longest delay	41

- a) On the grid, draw a box plot to show the information in the table.

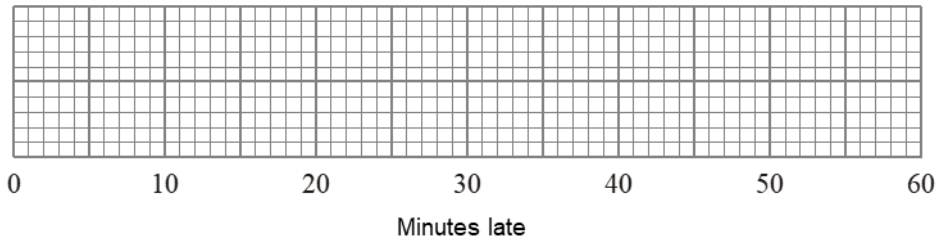

(2)

Melanie also went to the train station on Saturday. She recorded the number of minutes that each train was delayed. The box plot below was drawn using this information.

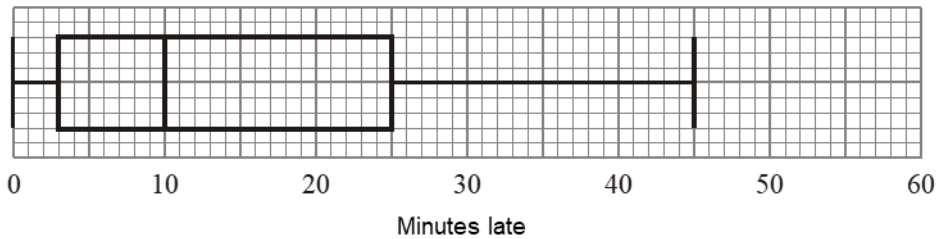

- b) Make two comparisons between the distributions of train delays on Friday and on Saturday.

.....

.....

.....

.....

(2)

(Total 4 marks)

Petersen Capture-Recapture Method

Things to remember:

- Set up a pair of equivalent fractions \rightarrow how many out of x were tagged = how many of the second sample are tagged out of how many in the original sample.
- This method assumes that the original sample is thoroughly mixed back in.

Questions:

1. A scientist wants to estimate the number of fish in a lake.
He catches 50 fish from the lake and marks them with a dye.
The fish are then returned to the lake.
The next day the scientist catches another 50 fish.
4 of these fish are marked with the dye.
Work out an estimate for the total number of fish in the lake.

.....
(Total 2 marks)

2. A farmer wants to estimate the number of rabbits on his farm.
On Monday he catches 120 rabbits.
He puts a tag on each rabbit.
He then lets the rabbits run away.
On Tuesday the farmer catches 70 rabbits.
15 of these rabbits have a tag on them.
Work out an estimate for the total number of rabbits on the farm.

.....
(Total 2 marks)

3. There are n beads in a jar.
40 of these beads are black.
Julie takes at random a sample of 50 beads from the jar.
5 of the beads in her sample are black.
Work out an estimate for the value of n .

.....
(Total 2 marks)

4. Clive wants to estimate the number of bees in a beehive.
Clive catches 50 bees from the beehive.
He marks each bee with a dye.
He then lets the bees go.
The next day, Clive catches 40 bees from the beehive.
8 of these bees have been marked with the dye.

- i) Work out an estimate for the number of bees in the beehive.

..... bees

- ii) Write down any assumptions you have made.

.....
.....
.....

(Total 4 marks)

5. Toga wants to estimate the number of termites in a nest.
On Monday Toga catches 80 termites.
He puts a mark on each termite.
He then puts all 80 termites back in the nest.
On Tuesday Toga catches 60 termites.
12 of these termites have a mark on them.
Work out an estimate for the total number of termites in the nest.

.....
(Total 2 marks)

6. There are a large number of white beads in a bag.
There are only white beads in the bag.
Felicity wants to find an estimate for the number of beads in the bag.
Felicity replaces 30 of the white beads in the bag with 30 black beads.
She then takes 50 beads from the bag.
2 of the 50 beads are black.
Felicity then puts the 50 beads back in the bag.

- a) Work out an estimate for the number of beads in the bag.

.....
(2)

- b) Write down one assumption you have made.

.....
.....
(1)

(Total 3 marks)

7. Alex wants to find out how many ducks there are in a park.

One day he puts a tag on each of 30 of the ducks.
The next day he catches 40 ducks.
8 of these ducks have tags on them.

- i) Work out an estimate for the number of ducks in the park.

.....

Alex assumed that none of the tags fell off during the night.

- ii) If Alex's assumption is wrong, explain how this could affect your answer to part (i).

.....

.....

(Total 4 marks)

Conditional Probability

Things to remember:

- In each of these questions, the second (and third) events are dependent on what the outcome is of the first event
- Start by drawing a probability tree for each question
- Remember in probability, 'and' means \times and 'or' means $+$

Questions:

1. Each day Andrew wears either a black tie or a red tie to work.
On Monday the probability he wears a black tie is 0.4
If Andrew wears a black tie on Monday, the probability that he will wear a black tie on Tuesday is 0.2
If he does not wear a black tie on Monday, the probability that he will wear a black tie on Tuesday is 0.7
Work out the probability Andrew wears different coloured ties on Monday and Tuesday.

.....
(Total 5 marks)

2. There are 8 counters in a bag.
5 of the counters are red.
3 of the counters are blue.
Two counters are taken at random from the bag.
Work out the probability that one counter of each colour are taken.
You must show your working.

.....
(Total 4 marks)

3. There are 10 counters in a bag.
5 of the counters are red.
3 of the counters are blue.
2 of the counters are green.
Ailee takes two counters at random from the bag.
Work out the probability that both of the counters Ailee takes are the same colour.
You must show your working.

.....
(Total 4 marks)

4. There are 9 sweets in a bag.
Five sweets are purple, three sweets are white and one sweet is pink.
Three sweets are selected at random **without** replacement.
Calculate the probability that the sweets are **not** all the same colour.

.....
(Total 5 marks)

5. Maisie has 10 cards, each with a number on it.



She picks three cards at random, without replacement.
Maisie adds the three numbers together to get a score.
Calculate the probability that the score is an odd number.

.....
(Total 5 marks)

Product Rule for Counting

Things to remember:

- To find the total number of outcomes for two or more events, multiply the number of outcomes for each event together
- Be wary of repeats though – sometimes they count and sometimes they do not

Questions:

1. There are 6 starters and 8 main courses in a restaurant.
Work out the total number of ways of choosing a starter and a main course.

.....
(Total 2 marks)

2. There are 11 boys and 16 girls in a choir.
One boy and one girl will be selected to sing a duet.
Work out the total number of ways of choosing a boy and a girl.

.....
(Total 2 marks)

3. Mr Peveritt has 5 pairs of trousers, 9 shirts and 3 ties.
Work out the total number of ways of choosing a pair of trousers, a shirt and a tie.

.....
(Total 2 marks)

4. There are 9 sandwiches and x drinks to choose from for lunch. Katie says there are 72 different ways to choose a sandwich and a drink. Could Katie be correct? You must show your working.

.....
(Total 2 marks)

5. There are 52 cards in a deck. Idriss is going to give one card to Aria and one card to Maya. How many different ways are there of doing this?

.....
(Total 2 marks)

6. There are 52 cards in a deck. Joe is going to give two cards to Prince. How many different pairs of cards could Prince get?

.....
(Total 2 marks)

7. There are 12 teams in a football league. Two teams are going to be chosen at random to play a match. Work out the number of different matches that could take place.

.....
(Total 2 marks)

8. There are 15 teams in a competition.
Each team will play every other team once.
Work out the total number of games played.

.....
(Total 2 marks)

9. There are 20 people in a room.
Each person shakes each other person's hand once.
Work out the number handshakes that take place.

.....
(Total 2 marks)

Direct and Inverse Proportion

Things to remember:

- Start by checking the question for squares, cubes and roots
- “ x is directly proportional to y ” looks like $x \propto y$ or $x = ky$
- “ x is inversely proportional to y ” looks like $x \propto \frac{1}{y}$ or $x = \frac{k}{y}$
- Find the proportion constant and then the proportion equation
- Substitute any given values into the proportion equation

Questions:

1. y is directly proportional to x
 y is given by the formula $y = 0.5x$
Find the value of y when $x = 8$

.....
(Total 2 marks)

2. y is inversely proportional to x
 y is given by the formula $y = \frac{3}{x}$
Find the value of y when $x = 12$

.....
(Total 2 marks)

3. y is directly proportional to the square of x
 y is given by the formula $y = 2x^2$
Find the value of y when $x = 8$

.....
(Total 2 marks)

4. d is directly proportional to the square of t
 $d = 80$ when $t = 4$

a) Express d in terms of t

$$d = \dots\dots\dots (3)$$

b) Work out the value of d when $t = 7$

$$d = \dots\dots\dots (1)$$

c) Work out the positive value of t when $d = 45$

$$t = \dots\dots\dots (2)$$

(Total 6 marks)

5. f is inversely proportional to d
When $d = 50$, $f = 256$
Find the value of f when $d = 80$

$$f = \dots\dots\dots (Total 3 marks)$$

6. g is directly proportional to the square root of h
When $g = 18$, $h = 16$
Find the possible values of h when $g = 2$

$h = \dots\dots\dots$
(Total 3 marks)

7. y is inversely proportional to the cube of x
When $y = 250$, $x = 0.2$
Find the value of y when $x = 0.5$

$y = \dots\dots\dots$
(Total 3 marks)

Reverse Percentages

Things to remember:

- Start by working out what the multiplier would have been, then divide by that multiplier

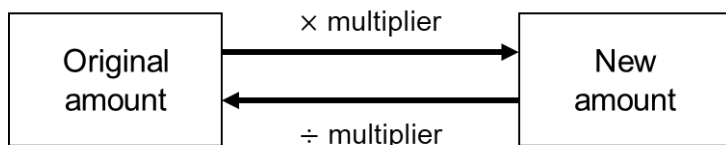

Questions:

1. Dylan's weekly pay this year is £600
This is 20% more than his weekly pay last year.
Reg says, 'this means Dylan's weekly pay last year was £480'
Reg is wrong,

- a) Explain why.

.....
.....

(1)

- b) Work out Dylan's weekly pay last year.

£

(2)

(Total 3 marks)

2. In a sale, normal prices are reduced by 25%
The sale price of a suit is £48
Calculate the normal price of the suit.

£

(Total 3 marks)

3. In a sale, normal prices are reduced by 12%
The sale price of a TV is £242
Work out the normal price of the TV

£
(Total 3 marks)

4. The price of all rail season tickets to London increased by 4%.

- a) The price of a rail season ticket from Cambridge to London increased by £121.60
Work out the price before this increase.

£ (2)

- b) After the increase, the price of a rail season ticket from Brighton to London was
£2828.80
Work out the price before this increase.

£ (3)
(Total 5 marks)

5. Gary invested money into a bank account.
Each year the money in the account earns 3% interest.
After one year, the total amount of money in the account was £169.95
How much did Gary invest?

£
(Total 3 marks)

6. Abi is given a 22% pay rise.
Her new salary is £21960
What was Abi's salary before the pay rise?

£
(Total 3 marks)

7. An oil tank has sprung a leak and loses 77.5% of its contents.
There is now 333 litres of oil in the oil tank.
How much oil was in the oil tank before the leak?

..... litres
(Total 3 marks)

Converting Recurring Decimals to Fractions

Things to remember:

- Dot notation is used with recurring decimals. The dot above the number shows which numbers recur, for example $0.5\dot{7}$ is equal to $0.57777\dots$ and $0.\dot{2}\dot{7}$ is equal to $0.272727\dots$
- When 1 digit recurs, multiply by 10 so that the recurring digits after the decimal point keep the same place value
- When 2 digits recur, multiply by 100 so that the recurring digits after the decimal point keep the same place value
- Similarly, when 3 digits recur multiply by 1000 and so on

Questions:

1. Prove algebraically that the recurring decimal $0.\dot{4}$ can be written as $\frac{4}{9}$

(Total 2 marks)

2. Prove algebraically that the recurring decimal $0.\dot{4}\dot{5}$ can be written as $\frac{5}{11}$

(Total 3 marks)

3. Prove algebraically that the recurring decimal $0.2\dot{3}$ can be written as $\frac{7}{30}$

(Total 3 marks)

4. Write $0.1\dot{8}$ as a fraction in its simplest form.

.....
(Total 2 marks)

5. Prove algebraically that the recurring decimal $0.21\dot{6}$ can be written as $\frac{8}{37}$

(Total 2 marks)

6. Write $0.35\dot{4}$ as a fraction in its simplest form

.....
(Total 3 marks)

7. Work out $0.\dot{5}4 \times 0.\dot{5}$

.....
(Total 4 marks)

8. Work out $0.\dot{3}9 \div 0.\dot{6}3$

.....
(Total 4 marks)

Useful websites:

www.piximaths.co.uk

www.mathswatchvle.com

www.corbettmaths.com

www.mymaths.co.uk

www.dr frost.com

**www.bbc.co.uk/schools/gcsebitesize
/maths**

**Remember: Do your best;
it is all you can do 😊**